

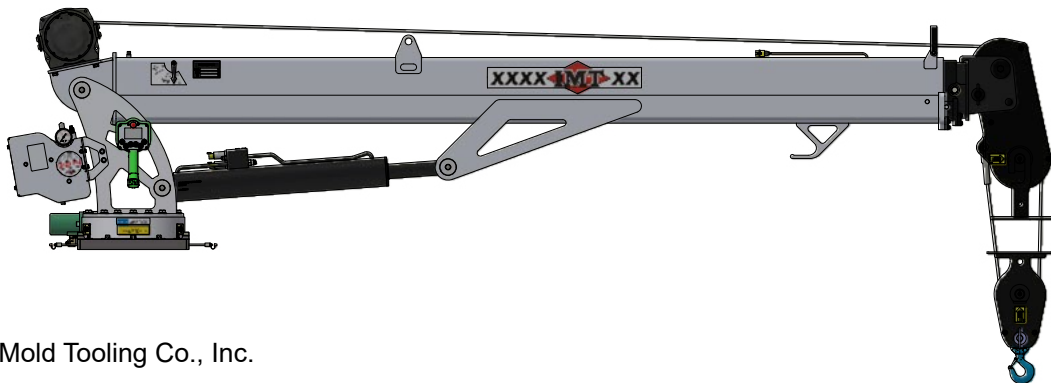

IOWA MOLD TOOLING CO., INC.

P.O. Box 189  
Garner, IA 50438  
Tel: 641-923-3711  
[www.imt.com](http://www.imt.com)



© 2026 Iowa Mold Tooling Co., Inc.

**Read, understand, and follow all safety information in this manual. Keep this manual with the vehicle at all times.**

Iowa Mold Tooling Co., Inc. (An Oshkosh Corporation Business)

Revised: 03-05-2026



## Disclaimer

### NOTICE

If your crane is involved in a property damage accident, contact your IMT Distributor immediately and provide them with the details of the accident and the serial number of the crane. If an accident involves personal injury, immediately notify your distributor and safety director:

Iowa Mold Tooling Co., Inc.  
500 HWY 18 W  
Garner, Iowa 50438  
641-923-3711  
800-247-5958

For assistance in ordering Publications, contact:

U.S. Department of Labor / OSHA  
OSHA Publications  
200 Constitution Ave NW  
Washington, D.C. 20210  
Telephone: 800-321-6742



[www.OSHA.gov](http://www.OSHA.gov)

## Proposition 65

### ⚠ WARNING

Operating, servicing and maintaining this vehicle or equipment can expose you to chemicals including engine exhaust, carbon monoxide, phthalates, and lead, which are known to the State of California to cause cancer and birth defects or other reproductive harm. To minimize exposure, avoid breathing exhaust, do not idle the engine except as necessary, service your vehicle or equipment in a well-ventilated area and wear gloves, or wash your hands frequently when servicing. For more information go to [www.P65Warnings.ca.gov](http://www.P65Warnings.ca.gov)



*California P65 Warning*



## 1.0 Product Identification

Please record your product's identification and purchase information which will help in the event you have questions or need any service.

Model:	Date of Purchase:
Serial #:	Seller Name / Address:

## 2.0 Purpose of Manual

This Operator's Manual provides operation and operator maintenance instructions for Telescopic Cranes manufactured by Iowa Mold Tooling Co., Inc

This manual is limited to the operation and light maintenance of the crane system only.

This manual does not include the operation or maintenance of the body vehicle upon which the crane system is mounted.

The operator of this vehicle must be properly licensed and trained to operate this vehicle. If you do not have the proper training and licensing to operate this vehicle, you are putting yourself and others at risk of serious injury or death.

If you are uncertain how to operate the crane, inform your supervisor or contact:

Iowa Mold Tooling Co., Inc.  
800-247-5958

**KEEP THIS MANUAL WITH THE VEHICLE AT ALL TIMES.**

## 3.0 Scope

This manual provides information for use by the equipment operator under the following headings:

1. **Important Safety Information.** Includes important safety information.
2. **Crane Transport.** Includes control functionality and normal equipment operation.
3. **Preparing To Operate.** Includes basic preventive maintenance information for the operator.
4. **General Operations.** Includes the step-by-step operations of the crane.
5. **Troubleshooting.** Includes answers to common

occurrences.

6. **Maintenance.** Includes daily, weekly, and monthly maintenance schedules.
7. **General Information.** Includes quick guides, QR codes for all Telescopic Crane manuals, and how to program the Association screen for the CMD. CTRL™ Radio Remote and Base Unit.

To order a replacement manual or safety warning decals, contact your IMT Distributor. Visit <https://imt.com/distributor-locator> to find a distributor near you.

## Parts and Service

Contact IMT Technical Support for assistance in looking up IMT part numbers. Parts must be ordered through an IMT Distributor.

Contact by phone 800-554-4421 or visit [www.imt.com](http://www.imt.com)



[www.imt.com/parts-service](http://www.imt.com/parts-service)

## Corporate Headquarters

Contact Iowa Mold Tooling Co., Inc. directly at the following address, phone number, and website.

500 Highway 18 West

PO Box 189

Garner, IA 50438-0189

Telephone: 641-923-3711

Toll Free: 800-247-5958

Website: [www.imt.com](http://www.imt.com)



[imt.com](http://imt.com)



1.0 IMPORTANT SAFETY INFORMATION.....1

1.1 Responsibilities .....1

1.1.1 Dealer Responsibilities.....1

1.1.2 Owner / Employer Responsibilities.....1

1.1.3 Employee (Operator, Maintenance, Other Personnel) Responsibilities .....2

1.1.4 Learn About the Equipment.....3

1.1.5 Additional Information.....3

1.1.6 Manual and Safety Decal Maintenance.....4

1.2 Personnel Qualifications and Requirements .....4

1.2.1 Required Operator Knowledge and Training.....4

1.2.2 Operator’s Physical Condition.....5

1.2.3 Wear Personal Protective Equipment (PPE).....5

1.3 Product Safety .....5

1.3.1 General Crane Hazards .....6

1.3.2 Electrocution Hazard .....7

1.3.3 Hydraulic Fluid Hazards .....8

1.3.4 Approved Modifications Only.....8

1.4 Explanation of Signal Words and Safety Symbols .....8

1.5 Reporting Safety Defects .....9

2.0 SAFETY OPERATIONS .....10



2.1	Crane Transport .....	10
2.1.1	Transportation Precautions .....	10
3.0	PREPARING TO OPERATE.....	10
3.1	Inspection Requirements.....	11
3.1.1	Inspections Are Required .....	11
3.1.2	Pre-Operation Inspections.....	11
3.1.3	Continually Monitor for Problems .....	12
3.2	Operation in Adverse Conditions.....	13
3.2.1	Extreme Cold Weather .....	13
3.2.2	Other Adverse Conditions .....	13
3.3	Electric Power Lines—Safe Work Practices.....	14
3.3.1	Procedures for Assembly & Disassembly.....	14
3.3.2	Procedures for Traveling with No Load Under or Near Power Lines.....	16
3.3.3	If You Come in Contact with a Power Line .....	16
4.0	PREPARING THE WORKSITE .....	16
4.1	Before the Lift.....	16
4.2	Deploying the Stabilizers.....	17
4.2.1	Stabilizer Operations .....	18
4.2.2	Example Load Capacity Chart.....	20



4.3 CMD.CTRL™ Display Screen (Base) .....20

    4.3.1 Display screen and keypad .....20

    4.3.2 Splash Screen .....21

    4.3.3 Main Menu.....22

    4.3.4 CMD.CTRL™ Radio Remote .....22

    4.3.5 How to Power Up Handheld Remote: .....23

    4.3.6 Radio Remote Screen Order.....23

4.4 Hand Signals .....25

4.5 Personal Fall / Tie-Off Protection.....25

4.6 Operating the Crane .....26

    4.6.1 Appropriate PPE.....26

    4.6.2 Prepare To Operate.....27

    4.6.3 Check Capacity and Load .....27

    4.6.4 Prior To Lifting A Load .....27

    4.6.5 Extending The Crane .....28

    4.6.6 Check Safety Of Lift .....28

    4.6.7 Lifting the Load.....28

    4.6.8 When Lift Is Completed .....29

    4.6.9 Overload Protection.....29

4.7 Receiver Display (Base Unit) .....30



4.7.1	Troubleshooting Base Unit LED .....	30
4.7.1.1	Base Unit LED Diagnostic.....	30
4.7.2	Crane Shutdown.....	31
4.7.3	Stowing The Crane.....	31
5.0	MAINTENANCE .....	32
5.1	Crane Maintenance Safety.....	32
5.2	General Maintenance Practices .....	32
5.3	Recommended Oil & Grease .....	32
5.4	Grease Zerk Location.....	33
6.0	STABILITY.....	35
6.1	Stability Testing .....	35
6.1.1	Set-Up.....	35
6.1.2	Stability Test .....	35
6.1.3	Lifting Within The De-Rated Zone .....	37
7.0	ABOUT THE CRANE .....	38
7.1	Crane Component Identification.....	38
7.1.1	Decal Replacement Information.....	39
7.1.2	Identification Decal Parts List.....	39
7.1.3	Identification Decal Locations .....	42
7.2	Hydraulic Pump .....	44



---

8.0	WIRE ROPE, HITCHES, AND SLING LOADING INFORMATION.....	44
8.1	Wire Rope .....	44
8.1.1	Wire Rope Inspection Criteria .....	44
8.1.2	Wire Rope Lubrication.....	45
8.1.3	Basic Hitches.....	45
8.1.4	Sling Loading.....	46
8.1.5	Wire Rope Lay.....	46
8.1.6	Wedge Socket Attachment.....	46
8.1.7	Cable Thimble Attachment .....	46
8.1.8	Wire Rope Attachments.....	47
8.1.9	Wire Rope Maintenance.....	48
8.1.10	When To Replace Wire Rope .....	48
8.1.11	Hooks .....	49
8.1.12	Hook Precautions .....	49
8.1.13	Hook Inspection.....	50
8.1.14	New and Repaired Hooks .....	50
8.1.15	Hook Testing.....	50
8.1.16	Hooks In / Not In Regular Use.....	51
8.1.17	Reasons To Remove Hook From Service .....	51
8.1.18	Hook Inspection Checklist.....	52



---

9.0	PRE-OPERATION INSPECTION .....	53
9.1	Pre-Operation Correction .....	53
10.0	QUICK GUIDES CMD.CTRL™ BASE UNIT .....	60
10.1	Navigation .....	60
10.1.1	Navigation—Continued .....	60
10.2	Lights.....	61
10.3	PTO.....	61
10.4	Engine Start / Stop .....	62
10.5	Compressors .....	62
10.6	Crane.....	63
10.7	Stabilizers.....	63
10.8	Fault Codes .....	64
10.9	Intergrated Power Unit IPU .....	64
11.0	QUICK GUIDES CMD.CTRL™ RADIO REMOTE .....	65
11.1	Face Plate Identification .....	65
11.2	Toggle Identification.....	65
11.3	Top Bar Icons.....	66
11.4	Fixed Function Icons .....	66
11.5	Crane Operations .....	67
11.6	Light Operations .....	67



---

11.7	Stabilizer Operations .....	68
11.8	Operations .....	68
11.9	Compressor .....	69
11.10	Crane Icons .....	69
11.11	Light Icons.....	70
11.11.1	Light Icons—Continued .....	70
11.12	Operation Icons .....	71
11.13	Stabilizer Icons .....	71
11.14	Cab Controls.....	72
11.15	Association .....	72
11.16	GM/IH CV CHASSIS PTO SETUP .....	73
11.17	Telescopic Crane Parts Manuals .....	74
11.18	Association—Programming .....	74
12.0	SAFETY DECALS.....	77
12.1	Safety Decal Parts List.....	77
INDEX	.....	78

**THIS PAGE INTENTIONALLY LEFT BLANK**



# 1.0 Important Safety Information

## 1.1 Responsibilities

Thank you for purchasing an IMT telescopic crane. We at IMT believe that safety is paramount in the operation of our equipment. Please furnish a copy of this manual to all persons involved in the operation and maintenance of your IMT crane. IMT grants you, the purchaser, the right to reproduce this document for that purpose and to further the education in safe operation and maintenance.

We want you to be able to meet your material handling and lifting needs with this product, and following proper operating procedures is the best way to do this. This manual:

- Explains the operation and maintenance of this vehicle and equipment.
- Reviews basic principles of operation.
- Highlights common safety concerns and procedures.
- Gives recommendations for using and maintaining the equipment.
- Expects the operator has been fully trained to operate the vehicle and equipment.

### 1.1.1 Dealer Responsibilities

1. **Provide Relevant Manuals to Purchaser:** Verify that all component manuals and all other materials provided by IMT are with the unit.
  - Body Manual
  - Warranty Policies
  - Parts / Technical Specifications Manual
  - Crane Log
  - Operator's Manual
2. **Crane Stability Testing:** If you install the crane on a vehicle, you must complete a stability chart. If the crane or vehicle is modified or replaced with other equipment, stability must be recalculated and the crane capacity chart updated. See "6.1 Stability Testing" on page 35.

### 1.1.2 Owner / Employer Responsibilities

**Company Policies and Procedures:** The rules of conduct within an organization outlining the responsibilities of both employees and employers.

**Proper Training:** Strengthen the skills of every employee to a higher level of workplace knowledge and job performance. Encourage (if applicable) proper certification through accredited programs.

**Be Sure Employees are Qualified:** Be sure operators,

maintenance, and other personnel who will be in the vicinity of the equipment are qualified and have read and understand all applicable safety procedures. See “1.1.3 Employee (Operator, Maintenance, Other Personnel) Responsibilities” on page 2.

This manual and the product labels do not replace the need to be properly trained. Becoming a Certified Crane Operator (CCO) will extend the knowledge of owner and operators in the areas of proper operating procedures, safety concerns, and maintaining the equipment. Follow the links below for more information on how to become a CCO.



*National Commission for the Certification of Crane Operators.*

<https://www.nccco.org/nccco/certifications/mobile-crane-operator/certification-overview>

**Read, understand, and follow all OSHA, ASME / ANSI, and other regulations / standards that may apply to your work with this equipment. Follow the safest procedures to perform tasks with this equipment. If you are ever uncertain about a particular task, or the proper method of using or operating this equipment, ask your supervisor, ask a safety professional, consult this manual,**

**consult the industry regulations referenced in “1.1.5 Additional Information” on page 3, or visit:**



<https://www.osha.gov/laws-regs>

### **1.1.3 Employee (Operator, Maintenance, Other Personnel) Responsibilities**

**Read, understand, and follow** all safety information in this manual, the body manual, other documentation related to the equipment, and on-product labels. Follow all workplace rules, instructions, and training. Follow the safest procedures to perform tasks with this equipment. If you are ever uncertain about a particular task, or the proper method of using or operating this equipment, ask your supervisor, or consult a safety professional, consult this manual or [www.imt.com](http://www.imt.com), or visit [www.osha.gov](http://www.osha.gov).

**Do not use damaged equipment:** If this equipment, or any of its parts, becomes damaged or needs repair, stop using the equipment and contact an experienced service individual immediately.

## Using this Manual and the Safety Decals

**WARNING**

**Read this manual and on-product labels carefully. Learn how to inspect, use, test, and maintain this equipment correctly, and strictly follow all safety information and instructions contained in this manual and on the equipment, as well as any requirements of local, state, and federal law, industry standards, and any other applicable safety procedures. Failure to do so could result in death, serious personal injury, property damage, or damage to the equipment.**

### **1.1.4 Learn About the Equipment**

The information contained in this Operator's Manual is to help provide you with the knowledge necessary in the safe and proper operation of your crane. This information is not intended to replace any governmental regulations, safety codes, or requirements of insurance carriers.

Familiarization with this Operator's Manual, government regulations, hazards, and the specific operations of your crane is a necessity. The operation and maintenance of your crane must be done with caution, while following all safety procedures and applicable regulations.

### **1.1.5 Additional Information**

In addition to this manual and on-product safety decals, read the body manual and other documentation for this equipment.

Much of the material contained in this manual is specific to IMT cranes. Much of the general crane safety information is as presented by The American Society of Mechanical Engineers' latest revisions of Mobile and Locomotive Cranes (ASME/ANSI B30.5) industry safety standards. Users must follow the requirements of these standards regarding inspection, testing, operation, and maintenance. These publications are available from:

The American Society of Mechanical Engineers  
Two Park Avenue,  
New York, NY 10016-5990

Crane operators and their employers must comply with OSHA 29 CFR, Part 1926, Subpart CC and CAL-OSHA Title 8, Article 93 (California). If any questions concerning safe operation or maintenance arise, please contact IMT or your IMT distributor for clarification.

## 1.1.6 Manual and Safety Decal Maintenance

This manual should be considered a permanent part of the equipment and be kept available for easy reference by any user. Replacement or additional copies are available from [www.imt/support/servicemanuals/91729072](http://www.imt/support/servicemanuals/91729072)

Safety decals on the equipment must be replaced anytime they are damaged, missing, or cannot be read clearly. Failure to have proper decals in place can result in serious injury or death. If you require safety decals, please contact IMT Technical Support 800-554-4421. See “*7.1.2 Identification Decal Parts List*” on page 39 for parts list and decal locations.

Please remember that this manual and the product labels do not replace the need to be alert, to properly train and supervise users, and to use common sense when using this equipment.

## 1.2 Personnel Qualifications and Requirements

### 1.2.1 Required Operator Knowledge and Training

- Be adequately trained by competent and authorized persons.
- Be authorized and qualified with demonstrated

understanding of safe and proper operation, inspection, and maintenance.

- Meet all certification requirements including OSHA and other regulations.
- Read, understand and follow ALL information in this Manual.
- Read, understand and follow ALL labels, signs or placards on the equipment relating to the use and operation of the equipment.
- Know, understand, and follow ALL information for the safe and proper use and operation of this equipment, and ALL applicable OSHA or other regulations / standards / laws. See “*1.1.5 Additional Information*” on page 3.
- Know, understand, and follow emergency procedures necessary for safe use and operation, and safely respond to any mechanical breakdowns, limitations, or problems.
- Have knowledge and the ability to establish a safe work zone for other personnel, bystanders, property, or the equipment.
- Know, understand, and follow hand signals. See “*4.4 Hand Signals*” on page 25 and other communications for the safe and proper use and operation of the equipment.



In addition, the operator of this vehicle must be properly licensed and trained to operate this vehicle. If you do not have the proper training and licensing to operate this vehicle, you are putting yourself and others at risk of serious injury or death.

If you are uncertain how to operate the crane, inform your supervisor or contact:

Iowa Mold Tooling Co., Inc.  
800-247-5958

### **1.2.2 Operator's Physical Condition**

- Vision: At least 20/30 (Snellen chart) in one eye and 20/50 in the other, with or without the aid of corrective lenses.
- Normal depth perception and field of vision (peripheral vision).
- Ability to distinguish colors if color recognition or differentiation is required for safe operation.
- Adequate hearing, with or without a hearing aid.
- Sufficient strength, endurance, agility, and coordination to meet equipment operation demands.
- Meets all owner or employer physical or other requirements with full ability to safely and properly operate the equipment.
- Operation of a crane must not be performed by

persons under the influence of alcohol, drugs, medications, or any chemicals capable of impairing the abilities of that person.

### **1.2.3 Wear Personal Protective Equipment (PPE)**

Wear appropriate Personal Protective Equipment (PPE) as required by your company. IMT recommends hard hats, safety glasses or goggles, sturdy gloves, hearing protection, steel toe boots, and snug fitting sturdy long-sleeve shirt and long pants when operating or maintaining the crane.

Reflective clothing is recommended for employees operating the crane.

## **1.3 Product Safety**

Read, understand and follow the safety guidelines listed below and contained in this manual as well as on the vehicle itself to reduce the risk of serious injury or death and to promote reliable operation. Contact Iowa Mold Tooling Co., Inc if you require assistance or have questions.

For additional information on potential hazards: <https://shop.aem.org/en/AEM%20Safety/aem-safety-products/mobile-crane-safety-manual/>

## 1.3.1 General Crane Hazards

There are a number of potential hazards associated with the crane use. These include:

- **Electrocution.** You WILL be electrocuted if you are near a crane that approaches or contacts energized power lines. See “1.3.2 *Electrocution Hazard*” on page 7 and “3.3 *Electric Power Lines—Safe Work Practices*” on page 14.
- **Crane tip over.** The crane must be on firm, level ground and the stabilizers must be properly used. See “1.0 *Important Safety Information*” on page 1, “6.1 *Stability Testing*” on page 35, and “4.6.8 *When Lift Is Completed*” on page 29.
- **Impact from stabilizers.** A person can be hit while the stabilizers are moving out, crushed when they contact the ground, or pinched when they are retracted. See “4.2 *Deploying the Stabilizers*” on page 17.
- **Impact from moving crane or load.** Keep bystanders away. Anyone not required in the operation of equipment must be kept a safe distance away. A distance of 10'-0” (3.05 m) from the outermost range of the crane and its load is an absolute minimum.
- **Hazards from overloading.** Exceeding the crane’s

rated load capacity will cause structural damage and damage to winches and cables which can lead to serious injuries or death. See “4.6.3 *Check Capacity and Load*” on page 27 and the crane’s capacity placard to determine if your load is within capacity.

- **Wire rope hazards.** A broken wire rope can quickly and forcefully strike people nearby, and a dropped or out-of-control load can also strike people. See “8.1 *Wire Rope*” on page 44 and follow appropriate work practices.
- **Fall or crush hazard from riding on crane or load.** Never ride on boom, hook, or load. Never use crane to hoist personnel. Do not allow anyone to ride on boom, hook, load, or any other device attached to crane boom or loadline.
- **Fall from carrier vehicle.** Only stand on portions of the carrier vehicle that are intended for that purpose. Follow on-vehicle safety decals.
- **Hydraulic fluid hazards.** High pressure hydraulic fluid leaks will pierce skin. Injected fluid will injure or kill. Hot fluid and surfaces also pose a burn hazard. See “1.3.3 *Hydraulic Fluid Hazards*” on page 8.
- **General vehicle hazards.** Refer to carrier vehicle manual for safety information regarding general vehicle and driving hazards.

- **Shut down if there are any safety concerns.**  
Authorized operators have the responsibility and authority to shut down the equipment and end all use and operation in case of any unsafe condition, malfunction, mechanical problems, or other safety concerns with the equipment, personnel, or the job site.

For additional information on potential hazards:

<https://shop.aem.org/en/AEM%20Safety/aem-safety-products/mobile-crane-safety-manual/>



*AEM, Mobile Crane Safety Manual*

### 1.3.2 Electrocution Hazard



**You WILL be electrocuted if you are near a crane that approaches or contacts energized electric power lines. Cranes are not insulated! Tethered Radio Remotes are not insulated! Death or serious injury from touching, or being in or near a vehicle or a tethered remote control WILL happen if the crane becomes electrically charged.**

When possible, avoid working near power lines.

- Follow all procedures in Section 3.3 *Electric Power Lines* before operating in the vicinity of power lines. Comply with all OSHA Power Line Safety regulations for assembly / disassembly, deploying, or operating equipment.
- NEVER approach or contact electric power lines with any part of equipment or load. The minimum safe approach distance can be as far as 45 ft (14 m) or more, depending on voltage and conditions such as wind. Swaying and movement of equipment and power lines due to wind must be considered.
- ALWAYS make sure electric power lines are de-energized and visibly grounded BEFORE approaching or working near them. Assume all electric power lines are energized until the owner of those lines or the electrical utility authorities verify that the lines are de-energized and visibly grounded.

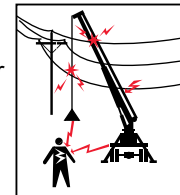

*Figure 1*

## 1.3.3 Hydraulic Fluid Hazards



Figure 2

### **WARNING**

#### HYDRAULIC FLUID HAZARDS

- High pressure fluid leak will pierce skin.
  - Release pressure before working on system.
- STAND CLEAR OF POTENTIAL HIGH PRESSURE HYDRAULIC FLUID LEAKS**
- Wear sturdy gloves and goggles. Detect leaks with wood or cardboard. NEVER use fingers.
  - Fluid injected in skin will injure or kill and must be surgically removed by trained doctor immediately or gangrene will result.

#### BURN HAZARD

- Oil temperatures may exceed 120°F (35°C).
- Do not touch hydraulic system.
- Hot surface can burn skin.

**CHECK HYDRAULIC HOSES, TUBES, AND PIPES DAILY.**

Call IMT Technical Support anytime you have questions concerning hydraulic hoses, tubes, or pipes:  
1-800-554-4421.

## 1.3.4 Approved Modifications Only

Modifications to your crane must be performed with IMT approved accessories, parts and optional equipment. If in doubt about the safety, compatibility, or appropriateness of any modifications, contact IMT before those modifications are made.

DO NOT make any alterations or modifications to any safety device, whether electrical, hydraulic, or mechanical. All safety devices must be inspected, tested, and maintained in proper working condition.

Update stability chart if needed. If the crane or vehicle is modified or replaced with other equipment, stability must be recalculated and the crane capacity chart updated. See "6.1 Stability Testing" on page 35.

## 1.4 Explanation of Signal Words and Safety Symbols

Signal words and safety symbols are two primary ways to call your attention to potential hazards. The following signal words are used throughout this manual and on product labels.

	<p>This is the safety alert symbol. It is used to alert you to potential physical injury hazards. Obey all safety messages that follow this symbol to avoid possible injury or death.</p>
	<p><b>DANGER</b> indicates a hazardous situation that, if not avoided, will result in death or serious injury.</p>
	<p><b>WARNING</b> indicates a hazardous situation that, if not avoided, could result in death or serious injury.</p>
	<p><b>CAUTION</b> indicates a hazardous situation that, if not avoided, could result in minor or moderate injury</p>
	<p><b>NOTICE</b> identifies practices, actions, or failure to act which could result in property damage or damage to the crane.</p>

Table 1

The “signal words” of **DANGER**, **WARNING**, and **CAUTION** have specific meanings to alert you to the relative level of hazard.

Take the safety warnings seriously. If you do not understand them or have questions about them, call Iowa Mold Tooling Co., Inc. at 1-800-554-4421.

### 1.5 Reporting Safety Defects

If you believe that your vehicle has a defect which could cause a crash or could cause injury or death, you should immediately inform the National Highway Traffic Safety Administration (NHTSA) in addition to notifying Iowa Mold Tooling Co., Inc. and the chassis manufacturer.

If NHTSA receives similar complaints, it may open an investigation, and if it finds that a safety defect exists in a group of vehicles, it may order a recall and remedy campaign. However, NHTSA cannot become involved in individual problems between you, your dealer, Iowa Mold Tooling Co., Inc., or the chassis manufacturer.

To contact NHTSA, you may call the Vehicle Safety Hotline toll-free at 1-888-327-4236 (TTY: 1-800-424-9153); go to <http://www.safercar.gov>; or write to: Administrator, NHTSA, 1200 New Jersey Avenue, SE, West Building, Washington, DC 20590. You can also

obtain other information about motor vehicle safety from <http://www.safercar.gov>.



*safercar.gov*

## 2.0 SAFETY OPERATIONS

### 2.1 Crane Transport

#### 2.1.1 Transportation Precautions

Before transporting the crane, adhere to the following precautions:

- The crane must be in its stored position.
- Stabilizers must be securely stowed and NOT extended horizontally or vertically.
- Hook and sheave assemblies must be securely fastened to prevent swinging.
- All loose accessories, tools, and remote controls must be securely stored in their respective compartments or fasteners.
- The PTO must be disengaged.

- The parking brake must not be released until all of the above procedures are completed.
- DO NOT drive the carrier vehicle while a load is present on the hook.
- DO NOT drive the carrier vehicle with less than the proper tire inflation pressure.
- DO NOT drive the carrier vehicle in areas where the vertical clearance is not known.
- DO NOT allow personnel to ride on the equipment during transport.

## 3.0 Preparing To Operate

The information contained in this Operator's Manual is to help provide you with the knowledge necessary in the safe and proper operation of your crane. This information is not intended to replace any governmental regulations, safety codes, or requirements of insurance carriers. Operators, maintenance, and test personnel must read and understand all safety procedures applicable to the equipment in use.

### 3.1 Inspection Requirements

See “9.1 Pre-Operation Inspection” on page 53. Additional copies of the Inspection Checklist can be found at [www.imt.com](http://www.imt.com) or by calling:

Iowa Mold Tooling Co., Inc.

Telephone: 800-554-4421

#### 3.1.1 Inspections Are Required

- Before each use or shift.
  - Monthly, quarterly and yearly.
  - As necessary during use and / or following any incident or when possible damage or problems occur.
1. Perform inspections more often if equipment is used in harsh or demanding conditions like extreme heat or cold weather.
  2. Always ensure all safety and instruction decals, placards, and labels are in place and legible.

### 3.1.2 Pre-Operation Inspections

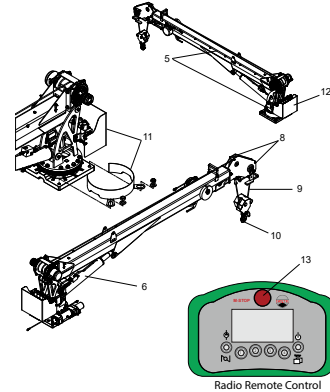

Figure 3

## ⚠ WARNING

**Do not operate equipment until all items on the Inspection Checklist and specified in this section are completed, and any needed corrective actions are performed by a qualified and competent person.**

**NOTE:** Items 1, 2 ,3, 4, 7, 14 of the Pre-Operation Inspections are not shown in *Figure 3*.

1. CHASSIS. Check oil level, battery, lights , and brakes.
2. TIRES. Check for proper inflation pressure, cuts, and loose or missing wheel lugs.
3. SAFETY ACCESSORIES. Check for proper function, oil levels, leaks, and malfunctions.
4. HYDRAULIC OIL RESERVOIR. Check for proper oil level, leaks, and blockages.
5. WELDMENTS. Check visually for damage, especially cracks or breaks in welds.
6. CYLINDERS. Check for leakage and scored cylinder rods.
7. FASTENERS. Check pins, sheaves, nuts and bolts for breakage, excessive wear, and tightness.
8. SHEAVES. Check for defects which could damage wire rope.
9. ROPES AND SLINGS. Check for frayed edges, broken strands, kinks, flat spots, and end attachments.
10. CRANE HOOKS. Check for the presence of a safety catch, twists, cracks, or damage.
11. COVERS AND GUARDS. Check for missing or improperly maintained covers and guards.
12. OPERATION PLACARDS AND SAFETY DECALS.

Check for illegible or missing decals and placards.

13. ENGINE STOP SWITCH ON REMOTE OPERATED CRANES. Check for proper operation and the presence of corrosion. NOTE: E-Stop switch will shut-off engine as well as hydraulics.
14. WORK AREA. Check for hazards such as powerlines, obstructions, etc.
15. ALWAYS ensure all safety devices that are identified throughout this manual are in place and operating properly.

The inspections and checks (1-15) must be made on a daily basis.

### **3.1.3 Continually Monitor for Problems**

At start-up and throughout operation, monitor for any problems listed in “9.1 Pre-Operation Correction” on page 53.

## **WARNING**

**Shut down the equipment if any safety concerns are observed. Failure to shut down equipment could result in serious injury.**



## 3.2 Operation in Adverse Conditions

### 3.2.1 Extreme Cold Weather

For cold weather operation with temperatures of -25° F (-32°C) or lower, the following procedures must be followed:

1. Start the truck and run at manufacturer's recommended idle speed for proper warm up.
2. After approximately 45 minutes of truck warm-up time, engage the PTO.
3. With manual transmissions only, at engine idle, release the clutch pedal until the PTO is fully engaged.
4. With the PTO fully engaged and the truck engine running at idle speed, let the hydraulic system oil circulate.

**NOTE:** If at any time during oil circulation, and especially during the initial warm up time, any hydraulic pump noise such as metal grinding, or a popping noise is heard, shut down the unit immediately. Check that the hydraulic oil line leading to the suction port on the pump is not clogged, or that the hydraulic oil itself has not jelled.

### 3.2.2 Other Adverse Conditions

Operating your crane in adverse conditions can affect the crane performance. Please note the following operation procedures for adverse weather conditions:

1. **DUSTY AND SANDY AREAS.** Operating in dusty or sandy areas presents special problems due to the abrasive action of dust which shortens the life of parts. Make every effort to keep dust and sand out of the moving parts of the crane machinery and engine. Keep lubricants clean, and lubrication and fluid fill areas capped tightly.
2. **HIGH HUMIDITY AND SALT AIR.** Moisture and salt will cause deterioration of paint, cables, wiring and all exposed metallic parts. Keep parts dry and well lubricated in high humidity or salt air conditions. Keep parts thoroughly lubricated, and remove rust and corrosion if and when it appears.
3. **HIGH ALTITUDES.** Operation at high altitudes presents special problems due to lower atmospheric pressure and wide temperature ranges. Consult the vehicle owner's manual regarding operating the vehicle at high altitudes.

### 3.3 Electric Power Lines—Safe Work Practices

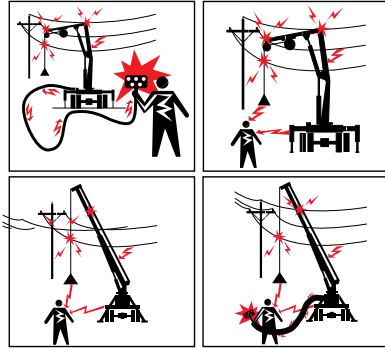

Figure 4

**⚠ DANGER**

**You WILL be electrocuted if you are near a crane that approaches or contacts energized electric power lines. The equipment is not insulated and does not provide protection from contact or proximity to electrical current. Death or serious injury will result from contact with, or proximity to, the vehicle or tethered remote control if the crane becomes electrically energized.**

- When possible, avoid working near power lines. **NEVER** approach or contact electric power lines

with any part of equipment or load.

- If you must work in the area of power lines, follow all procedures in this section before setting up or operating.
- When operating the crane by radio remote control, **LOOK UP**. Make sure there are no power lines.

#### 3.3.1 Procedures for Assembly & Disassembly

1. Follow ALL OSHA and Employer requirements. Read and follow ALL OSHA Power Line Safety regulations at [www.osha.gov](http://www.osha.gov) for assembly / disassembly, deploying, or operating equipment.
2. Conduct Planning Meeting. The operator and all workers in area of equipment or load must meet and review the location of the power lines and the steps that will be implemented to prevent encroachment / electrocution.
3. Use Only Non-Conductive Tag Line. If tag lines are used they must be non-conductive.
4. Determine and maintain Minimum Approach Distance (MAD), (*see Table 2*) between power lines and any part of the equipment, load line or load (including rigging and lifting accessories), when operated up to the equipment's maximum working radius. Allow for swaying and movement of the equipment and power lines due to winds.



MINIMUM APPROACH DISTANCE (MAD)		
VOLTAGE RANGE (Phase-To-Phase)	MIN. APPROACH (Distance in Feet)	MIN. APPROACH ( In Meters)
0 to 50 KV	10	3
OVER 50 KV TO 200 KV	15	5
OVER 200 KV TO 350 KV	20	6
OVER 350 KV TO 500 KV	25	8
OVER 500 KV TO 750 KV	35	11
OVER 750 KV TO 1000 KV	45	14

Table 2. Source: OSHA 1926.1408

**NOTE:** This requirement shall apply except where employer, local, or governmental regulations are more stringent. The Minimum Approach Distance may only be reduced by strictly following OSHA and any state or local rules and regulations and other safety requirements, and as determined by utility owner / operator working with a qualified registered professional engineer.

- Erect and maintain warning line or barricade. Erect and maintain an elevated warning line, barricade, or

line of signs within view of operator, and equipped with high-visibility markings at Minimum Approach Distance shown in Table 2.

- Have a dedicated spotter in continuous contact with operator. Dedicated spotter:
  - Must be equipped with a visual aid to identify Minimum Approach Distance;
  - Must be positioned to properly determine the Minimum Approach Distance;
  - Must have equipment, such as radios, or hand signals to communicate directly with operator.



**De-energizing and safely grounding electric power lines must only be done by utility owner / operator working with a qualified registered professional engineer, following OSHA and any state or local rules and regulation.**

**Assume all electric power lines are energized until the owner of those lines or the electrical utility authorities verify that the lines are de-energized and visibly grounded.**

**Death or serious injury WILL result from touching or being in or near vehicle, or a tethered remote**

### control if the crane becomes electrically charged.

#### **3.3.2 Procedures for Traveling with No Load Under or Near Power Lines**

- Always make sure crane is in full-lowered and properly stored position before moving.
- Avoid transporting crane over uneven terrain. Doing so can cause the crane to sway into power lines.
- Never allow any part of equipment to get closer than clearances in the Minimum Approach Distance table. (See *Table 2*)
- Always use a dedicated spotter properly positioned and in direct communication with operator to ensure required clearances are maintained.
- If you do not have enough visibility to ensure safe clearances from power lines, make sure the power lines are illuminated and the safe path of travel is identified and used.

#### **3.3.3 If You Come in Contact with a Power Line**

After situation is resolved:

- Replace any wire rope which may have contacted a power line.
- A complete vehicle inspection WILL BE required

before putting the equipment back into service.

 **DANGER**

**DO NOT MOVE** if there is doubt as to what may be electrically charged.

- **If you are in a cab of a vehicle, stay there. You WILL be electrocuted if you leave the cab while in contact with a power line.**
- **High voltage traveling through a crane will charge the ground below and around the crane. Avoid that area.**
- **Warn any personnel in the area of the presence of an electrical hazard.**
- **Call 911 or the local emergency service, such as a fire department, or ambulance service.**
- **Contact the utility company and have all power shut-off and lines de-energized.**

## 4.0 Preparing the Worksite

### 4.1 Before the Lift

1. Verify weather conditions are appropriate for operation. Wind speeds must be no greater

than 30 mph (19 kph). (Source, Code of Federal Regulations: Title 29 / Subtitle B / Chapter XVII / Subpart V §1926.968)

2. Before assembly / disassembly, deploying the equipment, or beginning any work:
  - The person in charge for the job must designate the work zone, which is the area around the equipment no smaller than the maximum working radius, reach, rotation, and height of the equipment.
  - Mark boundaries using flags, or range limit device, or range control.
3. The work zone must:
  - Be free from overhead power lines, trees, or other obstructions and hazards.
  - Have sufficient flat and level ground to position the vehicle within 5° of level.
  - Provide sufficient space for operating the crane and loading or unloading.
  - Allow for keeping bystanders out of work zone, and clear of the equipment.
  - Have a stable and solid surface to adequately support equipment, load, any related equipment or devices, and allow for proper stabilizer deployment.

- Have a suitable place to put the load if unloading, and allowing for proper positioning for picking up a load.

**NOTE:** Some concrete or asphalt surfaces are relatively thin and cannot withstand the stabilizer loading. Concrete can break through and cause instability.

4. Once vehicle is properly positioned, safely exit the vehicle and walk around the work zone to make sure it is suitable and safe, and that there are no overhead or other obstructions or hazards.

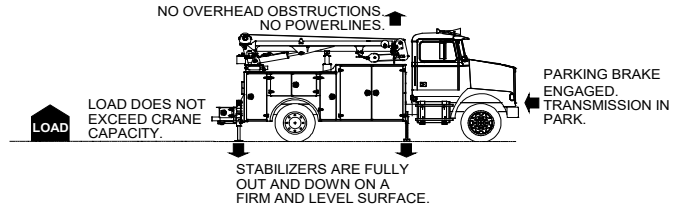

## 4.2 Deploying the Stabilizers

**NOTE:** IMT Telescopic Cranes are designed to be used with IMT Mechanic's Truck Chassis. Section 4.2 instructions details the operation of the stabilizers on an IMT Mechanic's Truck Body ONLY.

## 4.2.1 Stabilizer Operations

### **WARNING**

**Stabilizers can injure or kill people or damage objects—they can hit while moving out, crush when contacting the ground, or pinch while being retracted.**

Before extending stabilizers:

- Look around vehicle. Make sure NO obstructions are in or near the stabilizer path.

Keep visual contact with the stabilizer being deployed or retracted.

1. Make sure the job site is properly prepared as described in “4.0 Preparing the Worksite, which begins on page 16”.
2. Set the parking brake.
3. Prior to setting up the stabilizers, measure the height of the workbench from the ground.
4. Use blocks if necessary to level the unit on sloping ground. Use bearing pads if the stabilizers might sink into soft terrain or hot asphalt. (See pad manufacturer specifications for details regarding appropriate grade and size for needed ground support.)

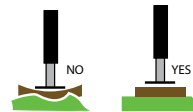

Figure 5

5. Level the crane side to side. With the compartment

door fully open, check the bubble level to verify that the crane is within 5° of level.

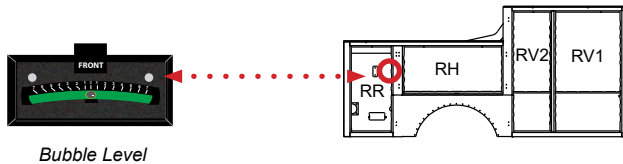

Figure 6

6. Extend the rear stabilizer arms:

- Hydraulic Stabilizer. Turn on the engine and engage the PTO. NOTE: The stabilizers can be operated from the radio remote control, or from the display unit in the Crane Compartment.
- Manual Stabilizer. Release the locking pin inside the RR compartment and extend the stabilizer arms until they lock into position.
- You should be able to see the words “Fully Deployed” on the yellow arrow decal on top of the stabilizer arms when the arms are fully extended. Lower the rear stabilizer legs until full ground contact is achieved with the truck leveled so that the weight on the chassis suspension springs is relieved enough to raise the workbench approximately 1” (2.54 cm). compartment.

**NOTE:** Set up both rear stabilizers prior to setting the front stabilizers. Front stabilizers are required to achieve the load rating indicated on the capacity chart.

7. Check the stabilizers, and if used, pads. Be sure the stabilizer is not sinking and the pad, if used, is not deformed. If the stabilizer pad deforms, the ground is not firm enough to use with that pad.

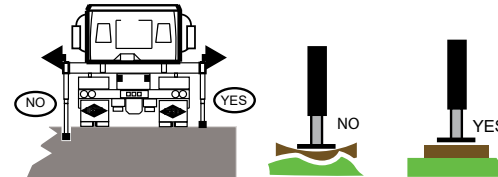

Figure 7

8. If you are not able to achieve solid, stable ground contact, and level the machine, relocate the equipment.
9. If the stabilizers are manual pull-out variety, make certain the arm pin is in place.

See *CMD.CTRL™ Crane Operator’s Manual* (PN: 91728524) for complete instructions on operating the stabilizers.

### 4.2.2 Example Load Capacity Chart

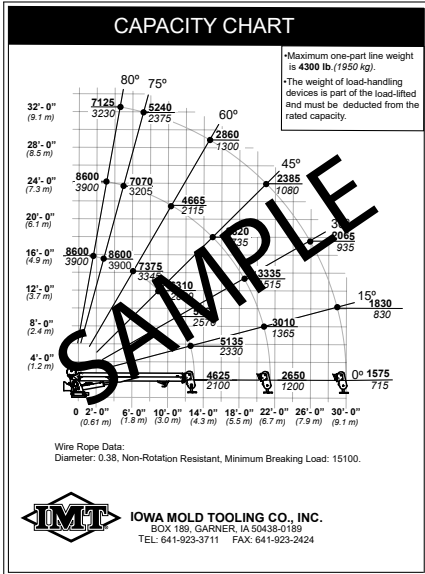
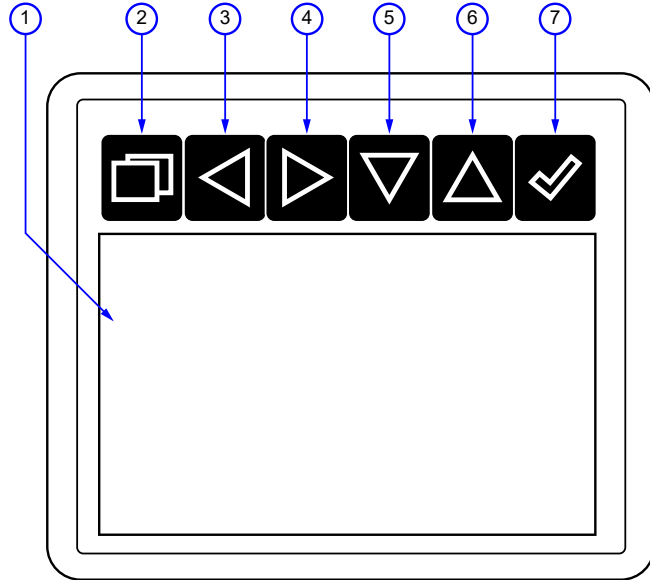

Figure 8

**NOTE:** The capacity placard shown in Figure 9 is an example only. The capacities are not intended for use on any particular telescopic crane.

## 4.3 CMD.CTRL™ Display Screen (Base)

### 4.3.1 Display screen and keypad



**NOTE:** The Display Screen is NOT a touch screen and is located in the crane compartment.

NO.	NAME	DESCRIPTION
1.	Display Screen	Displays text and graphic illustrations to the operator.
2.	Backspace	Exit back to the previous screen or back to the Main Menu.
3.	Directional Navigation Buttons	Move directionally to the left.
4.		Move directionally to the right**.
5.		Used to navigate to a currently highlighted item displayed on the Main Screen in both the left and right sidebars. Moves directionally up and down*.
6.		
7.	Select	Selects current highlighted configuration.

Table 3

Stabilizer Mode, the arrow buttons are used for operating the stabilizers.

\*\* Used for navigating the menus.

**NOTE:** The operator will use the buttons on top of the hand-held body module to navigate to the different menu options. If there are special requirements for the use of a button in a menu, there will be instructions on that specific screen indicating the operation of the button. Always follow instructions on the screen for button functionality. See “10.0 Quick Guides CMD. CTRL™ Base Unit” on page 60 for instructions.

### 4.3.2 Splash Screen

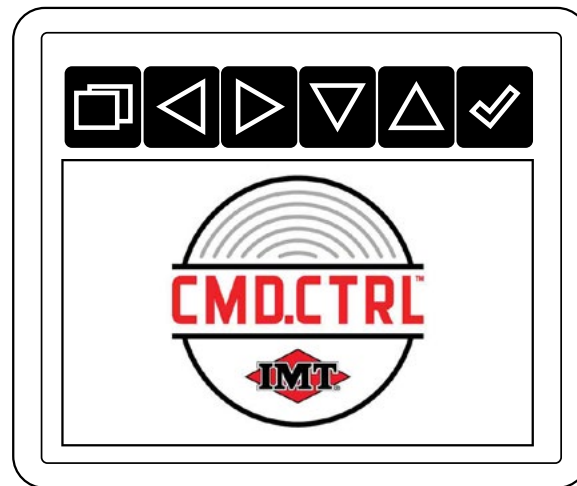

Figure 9

**NOTE:** The Splash Screen will be displayed the first 30 seconds after the system boots up, or until a key is pressed on the display. The module will display the Main Menu.

## 4.3.3 Main Menu

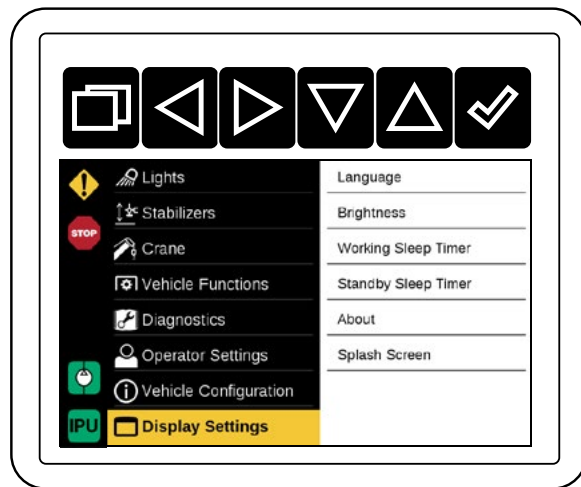

Figure 10

**NOTE:** The display will go into screen saver mode if no keys are active for a set time. The display will turn on when a key is pressed. This key press will only wake up the display and will not cause a screen selection or system operation.

See IMT manual part number 91728523, *CMD.CTRL™ Body Operator's Manual*, for complete step-by-step details on operating the CMD.CTRL™ display screen, or Quick Guides in Section 10.

## 4.3.4 CMD.CTRL™ Radio Remote

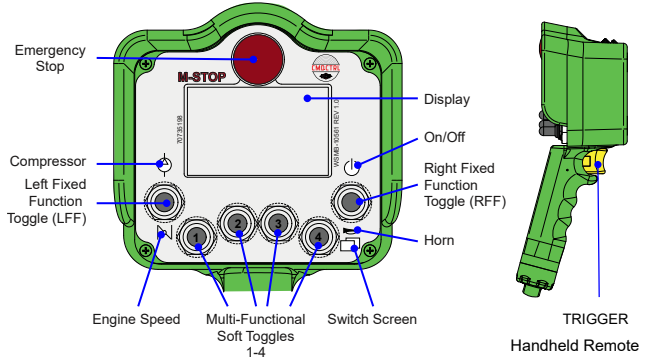

Figure 11

TOGGLE NAME	DESCRIPTION	TOGGLE STYLE
Right Fixed Function (RFF) UP	<ul style="list-style-type: none"> <li>TX ON / OFF</li> <li>Association</li> </ul>	Three-Position Momentary
Right Fixed Function (RFF) DOWN	<ul style="list-style-type: none"> <li>Horn</li> <li>Menu</li> </ul>	Three-Position Momentary
Soft Toggles 1 – 4	Functions will change based on the icons that are being displayed on the screen	Three-Position Momentary
Left Fixed Function (LFF) UP	<ul style="list-style-type: none"> <li>Compressor</li> </ul>	Three-Position Momentary
Left Fixed Function (LFF) DOWN	<ul style="list-style-type: none"> <li>RPM HI / LO</li> </ul>	Three-Position Momentary
Emergency Stop	Machine Stop	Maintained
Trigger	Proportional Control	Linear

Table 4 (On Page 22)

To change screens, click the RFF (Right Fixed Function) toggle switch downward briefly.

**NOTE:** If you hold and maintain the downward pressure on the RFF toggle, the horn will honk.

**4.3.5 How to Power Up Handheld Remote:**

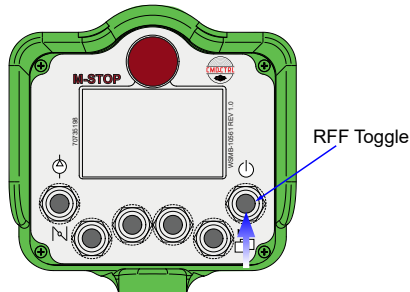

Figure 12

1. Toggle the Right Fixed Function (RFF) toggle UP for 1/2 second.
2. After a few seconds, the “CMD.CTRL™” splash screen appears:
3. Begin normal system operations when the Crane Operation Screen appears. See “4.3.6 Radio Remote Screen Order” on page 23.

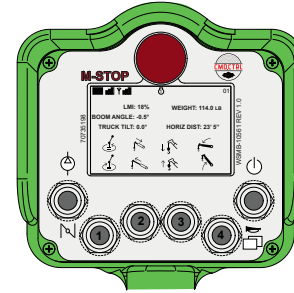

Figure 13 Crane Operation Screen

**4.3.6 Radio Remote Screen Order**

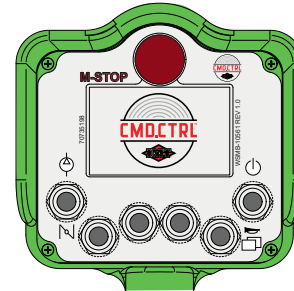

Figure 14 Splash Screen

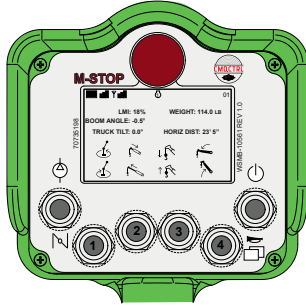

Figure 15, Screen 1, Crane Screen

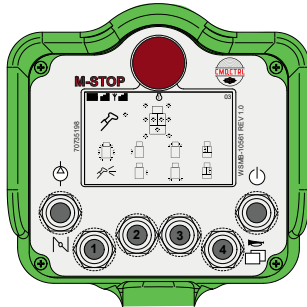

Figure 16, Screen 2, Light Screen

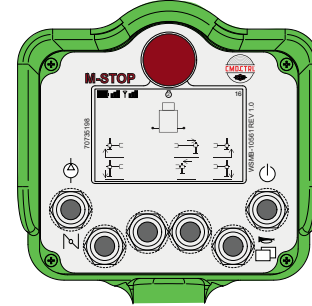

Figure 17, Screen 3, Stabilizer Screen

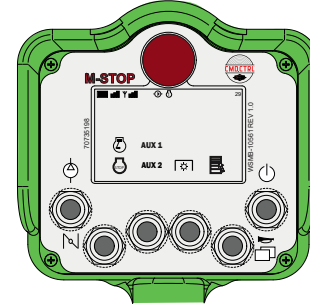

Figure 18, Screen 4, Operation Screen

For more information on how operate the CMD.CTRL™ Crane Radio Remote see IMT manual part number 91728524, or CMD.CTRL™ Quick Guides in Section 10. For information on Base Association, see General Information / Association in Section 11.

# General Operation

## 4.4 Hand Signals













 <p><b>RAISE BOOM TIP VERTICALLY</b> Arm extended, fingers closed, thumb pointed upward.</p>	 <p><b>LOWER BOOM TIP VERTICALLY</b> Arm extended, fingers closed, thumb pointed downward.</p>	 <p><b>INCREASE RADIUS OF BOOM TIP</b> Both fists in front of body with thumbs pointing outward.</p>	 <p><b>DECREASE RADIUS OF BOOM TIP</b> Both fists in front of body with thumbs pointing toward each other.</p>
 <p><b>SWING</b> Arm extended, point with finger in direction of swing of boom.</p>	 <p><b>MOVE SLOWLY</b> Use one hand to give any motion signal and place other hand motionless in front of hand giving the motion signal. (Hoist slowly shown as example.)</p>	 <p><b>STOP</b> Arm extended, palm down, move arm back and forth horizontally.</p>	 <p><b>EMERGENCY STOP</b> Both arms extended, palms down, move arms back and forth.</p>
 <p><b>HOIST LOADLINE</b> With forearm vertical, forefinger pointing up, move hand in small horizontal circle.</p>	 <p><b>LOWER LOADLINE</b> With arm extended downward, forefinger pointing down, move hand in small horizontal circle.</p>	 <p><b>RAISE THE BOOM TIP AND LOWER THE LOAD</b> With arm extended, thumb pointing up; flex fingers in and out and long as load movement is desired.</p>	 <p><b>LOWER THE BOOM TIP AND RAISE THE LOAD</b> With arm extended, thumb pointing down; flex fingers in and out and long as load movement is desired.</p>

Figure 19

Per OSHA 1926 Subpart CC, signals must be used when the operator's view of the load is obstructed or when the operator or the person handling the load determines signals are necessary.

Circumstances or work site rules sometimes require use of hand signals for communication. The illustrations in *Figure 19, Hand Signals*, includes each hand signal, the operation associated with the signal, and a description of the signal.

For operations not covered by the illustrated hand signals, additions to or modifications may be made but all signals must be agreed upon and understood before the crane is operated.

## 4.5 Personal Fall / Tie-Off Protection

When using IMT products for the purpose of personal fall protection, users shall read, understand, and follow the personal fall protection provisions of OSHA 29 CFR 1926.1423, paragraphs (g) Anchorage criteria; (j) Anchoring to the load line; (k) Training. **Note:** OSHA sections, 1926.502(d)(15)\* and 1926.502(e)(2)\*, are cross-referenced in this section and is up to the user to read, understand, and follow these regulations. The above-referenced provisions within OSHA address specific personal fall protection requirements; however, users of IMT products are required to read, understand

and follow all OSHA, industry, workplace, and employer-created regulations governing the use of this product, which includes, but is not limited to, 29 CFR 1926.1423. The user is also required to read, understand, and follow IMT's warnings and instructions. Nothing should be interpreted to limit compliance or excuse non-compliance with the above requirements in their entirety.

When using IMT products with personal fall protection as described above, users shall utilize a two-part line with the snatch block installed on the winch load line. The personal fall protection shall be attached to the hook on the snatch block. The personal fall protection device shall be connected to the hook on the snatch block only if the hook has the original safety latch on the hook.

In order to use this method, the hook must have a safety latch, the crane must be capable of supporting 5,000 pounds (refer to the load chart affixed to the crane), limit the fall to less than 6-feet, and not allow a swinging fall. Crane hooks should be used only where there is no other suitable anchor point.

At no time shall anyone use the hook on the snatch block for purposes of attaching personal fall protection if the safety latch is not original to the hook, or is missing or damaged, and / or if the safety latch is not properly functioning. At no time shall anyone use the winch wire-

rope as a tie-off point for personal fall protection.

### **WARNING**

**The failure to follow the above regulations and strict adherence to all applicable OSHA, industry, workplace, employer-created, and IMT warnings and instructions can lead to personal injury or death.**

These regulations can be found here:

[https://www.osha.gov/pls/oshaweb/owadisp.show\\_document?p\\_table=STANDARDS&p\\_id=67](https://www.osha.gov/pls/oshaweb/owadisp.show_document?p_table=STANDARDS&p_id=67)

## 4.6 Operating the Crane

All decals must be in place before the crane operations begins. If they are missing or illegible, replace them immediately.

### 4.6.1 Appropriate PPE

Use appropriate Personal Protective Equipment (PPE) as required by your company. Read and understand the following instructions found within this document prior to starting work on the chassis. IMT recommends the following OSHA PPE Standards:

- Ear Protection.
- Eye Protection. (Safety Glasses / Goggles)
- Head Protection. (Hard Hats)

- Foot Protection. (Steel-Toe Boots)
- Hand Protection.
- High Visibility Clothing.

Visit OSHA for additional PPE information.



*OSHA, PPE Equipment OSHA PPE Standards  
(29 CFR 1910)*

#### **4.6.2 Prepare To Operate**

Make certain the carrier vehicle's transmission is in neutral and the parking brake is on before engaging the PTO.

Operate the throttle control to achieve the proper engine speed.

#### **4.6.3 Check Capacity and Load**

The IMT crane is designed to lift specific loads. These loads are defined on the capacity placard mounted near the operator's station and on the crane. Exceeding the limits presented on the capacity placard will create severe safety hazards and will shorten the life of the

crane. The operator and other concerned personnel must know the load capacity of the crane and the weight of the load being lifted.

The capacity chart for each model is located in the specific crane technical specifications manual, and on placards on the crane and body.

#### **4.6.4 Prior To Lifting A Load**

1. Determine the weight of the load.
2. Determine the weight of any load handling devices.
3. Add the weight of the load and the weight of the load handling devices. The sum is the total weight of the load being lifted. This weight should not exceed the capacity noted on the chart at the position(s) at which the weight will be lifted.
4. Determine the distance from the centerline of crane rotation to the centerline of the load being lifted.
5. Determine the distance from the centerline of crane rotation to the centerline of the point to which the load should be moved.
6. Verify that the crane is positioned such that the boom will reach both the starting and ending points.
7. Determine the angle at which the crane will be operated (for example, 30° or 45°) by referencing the angle indicator on the lower boom.

8. Locate the load distance and angle on the capacity chart on your equipment and verify that you can lift the load.
9. Use two-part line for any lift which exceeds the capacity of a one-part line.

**NOTE:** The maximum one-part line weight is located at the top right hand corner of your load capacity chart.

### 4.6.5 Extending The Crane



## WARNING

**DO NOT attempt to rotate the crane before removing it from the stowed position. Damage to equipment and injury to personnel may result.**

1. Know the position of the booms at all times while operating the crane.
2. If the crane is equipped with a winch, lower the hook block to an adequate length to allow for extended boom length before extending any telescoping boom sections.
3. Raise the boom.
4. Rotate the boom to the selected location.
5. Position the boom tip directly over the center of the load before lifting to eliminate swing.

### 4.6.6 Check Safety Of Lift

1. Check the safety of the load when the crane is supporting the load.
2. Open the crane compartment door and leave open to reveal the bubble level to make sure the equipment is within 5° of level, (see *Figure 6*) and stabilizers are not sinking into the ground.

### 4.6.7 Lifting the Load

1. When lifting a load, keep it as close to the ground as possible. Most lift operations can be accomplished without great height.
2. Take precautions when rotating the crane load from areas that are supported by stabilizers to those supported by the carrier vehicle's tires and suspension—the support point can suddenly shift as tires or springs compress. Keep the load as close to the ground as possible and rotate smoothly.
3. If a function stops working due to overload, reverse the function which is causing the overload condition and reduce the load moment to bring the crane out of overload.

#### 4.6.8 When Lift Is Completed

Position the crane in its stowed position when not in use.

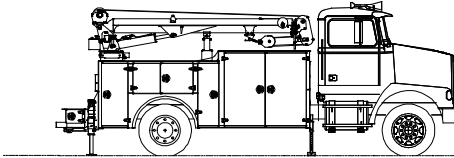

Figure 20

#### 4.6.9 Overload Protection

IMT cranes are equipped with an overload protection system. In an overload condition, NO function will operate which results in an increase in load moment. However, the same function may be operated in the opposite direction if it results in decreased load moment

Bear in mind that the overload protection system is not sensitive to carrier vehicle stability—it is still possible to cause vehicle instability. **The operator must be aware that the overload protection system is not a substitute for good judgement.** Always refer to the capacity and stability charts before attempting to lift a load.

Overload protection is built into the electrical system on radio-controlled cranes, and is hydraulic on manually

controlled cranes.

The overload protection system stops the following functions at the point of overload:

- Boom down.
- Boom extend.
- Winch up.

If a function stops working due to overload, reverse the function which is causing the overload condition, reduce the load moment, and bring the crane out of overload.

Test the overload system daily to determine if it is operating properly. If you determine that the overload system is not working properly, use the drawings in your crane parts manual to check the hydraulic overload kit on manually controlled cranes, and the controls system on remote controlled cranes.

To test the overload system:

- Lift any weight.
- Extend the weight.
- Verify that the percentage value on your remote is changing.
- This will let the operator know the system is operating correctly.
- When the display exceeds 100% the system will

enter overload and winch up, boom out, and main boom down will no longer function.

## 4.7 Receiver Diagnostic LEDs (Base Unit)

See the *Base Unit Display Error Messages, Table 5*.

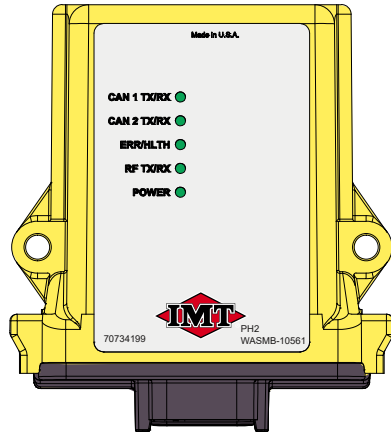

Figure 21

## 4.7.1 Troubleshooting Base Unit LED

### 4.7.1.1 Base Unit LED Diagnostic

BASE UNIT LED DIAGNOSTIC	
ISSUE	INDICATION
Power LED not active	Check input power polarity.
RF TX/RX not active	Check for obstructions preventing line-of-sight transmission.
	Check that the handheld remote is active.
	Reassociate the handheld remote to the base unit.
ERR / Health LED not blinking at 1Hz rate	Indicates an internal problem. Check the outputs for loose wiring etc. Check to see if current output or voltage input is out of bounds.

BASE UNIT LED DIAGNOSTIC	
ISSUE	INDICATION
Out LED not active	Check that the handheld LEDs are active when the appropriate buttons are pushed.
ERR LED active	Check the outputs for loose wiring, etc.
	Check to see if current output or voltage input is out of bounds
CAN 1 TX / RX not active	Unit is not communicating with system.
CAN 2 TX / RX not active	Unit is not communicating over the remote tether cable.

Table 5

#### 4.7.2 Crane Shutdown



**When storing a crane for long periods, or just for overnight, put the crane in its designed stowing position. Remove the keys and lock the carrier vehicle to prevent unauthorized operation of the crane and associated equipment. Unauthorized use can result in property damage, personal injury or death.**

#### 4.7.3 Stowing The Crane

1. Retract the extension boom (and cable if applicable).
2. Secure the hook.
3. Stow the crane in its travel configuration.
4. Stow the stabilizers.
5. Disengage the throttle control.
6. Disengage PTO, then release parking brake.
7. Secure loose items on truck bed.

# 5.0 MAINTENANCE

See “1.3.3 Hydraulic Fluid Hazards” on page 8.

## 5.1 Crane Maintenance Safety

1. Read and understand the following instructions found within this document prior to starting work on the crane.
2. Only qualified service personnel are to perform maintenance on the crane.
3. Follow your company’s Lock-Out Tag-Out procedures to prevent the truck from being started or moved while performing work on this crane. If your company does not have a Lock-Out / Tag-Out procedure, follow OSHA 1910.147, Lock-Out / Tag-Out and ANSI Z244.1 Control of Hazardous Energy: Lockout.
4. Use appropriate Personal Protective Equipment (PPE) as required by your company.
5. Disengage the PTO before any service or repair is performed.
6. Stand clear of high pressure hydraulic fluid leaks. Leaks can cause serious injury, burns and possibly DEATH.
7. DO NOT disconnect any hydraulic components or hoses while there is pressure in those components.

## 5.2 General Maintenance Practices

1. Keep the crane clean and free from built-up grease, oil and dirt to prevent slippery conditions and as an aid in the inspection of the crane.
2. Perform all checks before each period of use.
3. Replace parts with factory approved parts, only.
4. Immediately repair, or have repaired by a qualified technician, any components that are found to be inadequate.

## 5.3 Recommended Oil & Grease

Crane lubrication requirements are important for both maintenance and safety. By reducing friction on pins and gears the crane will be more reliable and safer to operate. Different lubricants are required for different sections of your crane. Contact your lubricant supplier for specific product information. Grease your crane per the following lubrication specifications and intervals.

## 5.4 Grease Zerk Location

LUBRICATION POINTS	FREQUENCY
Mast / planetary gear	After 20 hours of operation / weekly (whichever occurs first)
Pinion ball bearings	After 20 hours of operation / weekly (whichever occurs first)
Base bearings	After 20 hours of operation / weekly (whichever occurs first) (Rotate between stops during greasing)
Pins / bolts	After 20 hours of operation / weekly (whichever occurs first)
Control valves and rod connections	Oil spray as required

Table 6

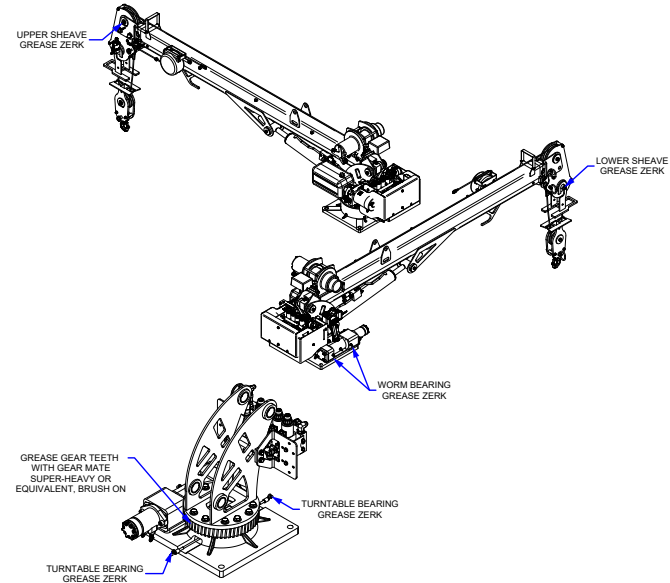

Figure 22

LOCATION	LUBRICANT	METHOD	FREQ.
Base - Turntable Bearing Grease Zerks	Extreme Pressure Lithium grease such as: Shell Alvania 2EP, Shell Retinax A, Mobilgrease XHP 462, Cenex ML 365®, Xtreme True-Flo EP2 Lithium grease or equivalent	Apply with hand or pneumatic pressure grease gun	Weekly
Snatch Block Pin			
Lower Sheave			
Upper Sheave			
Gear Teeth	GearMate® Super Heavy or equivalent	Brush	Weekly
Worm Gear	GearMate® Super Heavy or equivalent	Apply with hand or pneumatic pressure grease gun	

Table 7

The hydraulic oil for your crane is ISO VG32, low pour, anti-wear hydraulic oil. IMT recommends SAE oil based on the following temperature ranges:

SAE Designation	Temperature Range	Fill Recommendations														
5W-20	10 to 180° F (-23 to 82° C)	 <p>Iowa Mold Tooling Co., Inc. Garner, Iowa USA 641-923-3711</p> <p>HYDRAULIC OIL RESERVOIR FILL RECOMMENDATIONS</p> <table border="1"> <thead> <tr> <th rowspan="2">HYDRAULIC OIL</th> <th colspan="2">AMBIENT TEMPERATURE RANGE</th> </tr> <tr> <th>°F</th> <th>°C</th> </tr> </thead> <tbody> <tr> <td>ISO 32</td> <td>0° to 90°</td> <td>-18° to 32°</td> </tr> <tr> <td>ISO 15</td> <td>Below 0°</td> <td>Below -18°</td> </tr> <tr> <td>ISO 46</td> <td>Above 90°</td> <td>Above 32°</td> </tr> </tbody> </table> <p>For Arctic conditions, consult your oil supplier.</p>	HYDRAULIC OIL	AMBIENT TEMPERATURE RANGE		°F	°C	ISO 32	0° to 90°	-18° to 32°	ISO 15	Below 0°	Below -18°	ISO 46	Above 90°	Above 32°
HYDRAULIC OIL	AMBIENT TEMPERATURE RANGE															
	°F		°C													
ISO 32	0° to 90°	-18° to 32°														
ISO 15	Below 0°	Below -18°														
ISO 46	Above 90°	Above 32°														
10W	+10 to 180° F (-12 to 82° C)															
10W-30	+10 to 210° F (-12 to 99° C)															

Table 8

Maintaining a lubrication schedule will vary dependent on climatic conditions and the frequency of crane use. The lubrication chart shown in this section is intended to reflect crane lubrication requirements for units under normal working frequencies and normal weather conditions. Periods of heavy use and severe weather conditions will require more frequent lubrication.

## 6.0 Stability

### 6.1 Stability Testing

Every IMT factory-installed crane includes a completed stability chart. Any installer other than IMT also has the responsibility to complete a stability chart. Cranes are tested for stability to 85% of the balance point, which per SAE J765a is defined as “the capacity of the crane to support loads is based on its resistance to overturning.” Any additional loads will cause the truck to tip.

The values on the factory-installed stability chart are based on 85% of the balance point (tipping point) for a specific truck and crane combination. If the crane or vehicle is modified or replaced with other equipment, stability must be recalculated. By referring to the stability chart for your crane and body combination, it is possible to determine the loads permitted in the de-rated load range of your crane.

#### 6.1.1 Set-Up

1. Perform the stability test on a flat hard surface. Ideally this surface will be concrete, but asphalt or hard-packed gravel are acceptable. Only authorized testing personnel may be in or near the test area. Per SAE J765a, the area must be within 1° of level.

2. Prior to setting up the stabilizers, measure the height of the workbench from the ground.
3. Position the rear stabilizers. Level the truck so the weight on the springs is relieved enough to raise the workbench approximately 1” (2.54 cm).
4. Set up the front stabilizers. If they don’t touch the ground with the rear stabilizers as set in step #3, lower the rear stabilizers until the front stabilizers come in firm contact with the ground, then adjust the rear stabilizers until the truck is level.
5. Operate the crane under partial load to assure operator proficiency and proper machine function.

#### 6.1.2 Stability Test



**At 118% of rated capacity, you are in overload! Operate the crane very carefully. Keep the load within 4” (10 cm) of the ground at all times. Operate controls slowly.**

1. Once the stabilizers are properly set, rotate the crane to directly off the rear of the truck fully extended. Refer to Table 15 (on page 59) for the proper load and angle for your crane.

Test Load Value \_\_\_\_\_ (lb)

2. With the required weight at the required test angle, read the handheld remote or measure the horizontal reach.

Max. Horizontal reach \_\_\_\_\_ (L)

3. Slowly start rotating the load counterclockwise, keeping it within 4" (10 cm) of the ground to avoid excessive tipping.

**NOTE:** The tires can lift from the ground without the truck becoming unstable. If the crane carries the load through the entire area without becoming unstable, the crane is stable in that area and 100% can be noted in the box in that section.

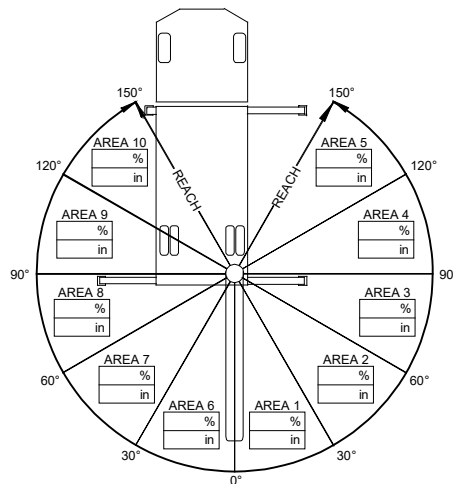

Figure 23 Stability Chart

4. If at any point through the rotation cycle, the vehicle becomes unstable, stop the rotation and note the area in which the crane is positioned.
5. At the balance point, retract the extension boom until stability is regained. Measure the horizontal reach in this position (center of rotation to hook). This is the stable horizontal reach in this zone. Note this reach in *Figure 23*.

## ⚠ WARNING

The “tipping point” is defined as the balance point (per SAE J765a) when the load on the crane is balanced with the load of the truck and stabilizers. Any additional load will cause the truck to tip. Cranes are tested for stability to 85% of the balance point.



6. Continue rotating the boom after stability has been regained. Again, watch the vehicle for instability. If a point of instability re-occurs, retract the extension boom until stability is regained. Again, determine the stable horizontal reach, and note this distance in *Figure 23*.
7. Repeat this cycle through a full 180°. Complete all of the reach boxes for Areas 1 through 5 in *Figure 23*.
8. Repeat for Areas 6 through 10.
9. If the crane was stable in all areas, fill in 100% in all of the percentage boxes in *Figure 23*.
10. If the stable horizontal reach in any area was less than the maximum horizontal reach (L, determined in step 2), divide the stable horizontal reach by the maximum horizontal reach. Multiply this figure by 100 to gain the percent of full capacity allowed in this area.

Stable Horizontal Reach / Test Position Horizontal Reach (L) x 100 = \_\_\_\_\_ %.

11. Using the data generated in *Figure 23*, fill out the stability capacity chart. In the de-rated zone, each individual capacity on the capacity chart must be multiplied by the de-rated percent of full capacity.

The figures obtained indicate the stability range of the particular truck and crane combination only. If either the truck or crane is changed or modified, the stability calculations must be repeated.

Contact IMT if you need a modified stability chart for your vehicle.

Rotate the crane at least five times using the completed figure to ensure the rating is accurate.

Be sure all information has been recorded on the appropriate figure, and in the service manual.

Record the total length of time to test the crane (total crane test and inspection time should approximate four hours per SAE J765a (1990)). Total Hours = \_\_\_\_\_.

When applicable, this stability test conforms to SAE J765a and ANSI B30.5.

### 6.1.3 Lifting Within The De-Rated Zone

If it is absolutely necessary to perform a lift within the de-rated load capacity zones, proceed as follows:

1. Determine the distance from centerline of rotation to the centerline of the load being lifted.
2. Determine the distance from centerline of rotation to the centerline of where the load is to be moved to.
3. The actual distance used should be figured as the

larger of items 1 and 2 above.

4. Refer to the crane's capacity placard and determine within which range the lift will be accomplished.
5. Refer to the capacity of that range and multiply that figure by the de-rated capacity percentage.
6. Make certain that the weight of the load plus any load handling devices does not exceed that figure.

### Example:

If the de-rated percent in Area 3 = 70% and crane capacity at the desired range = 2000 lb, then  $0.70 \times 2000 \text{ lb} = 1400 \text{ lb}$ . Even though the crane is rated for 2000 lb at that particular range, by making the lift within the de-rated load capacity zone the load must not exceed 1400 lb.

## 7.0 About The Crane

### 7.1 Crane Component Identification

Know the components of your crane. Doing so will aid in the communication of problems to maintenance personnel as well as provide immediate reference during an emergency situation.

Refer to the illustrations provided in this section.

Determine the type of crane specific to your operation and study the illustrations of main assemblies and hydraulic components. This reference is to IMT cranes specifically and should not be considered universal. There are variances between different crane models and the illustrations should be used as reference and compared to the actual equipment in use.

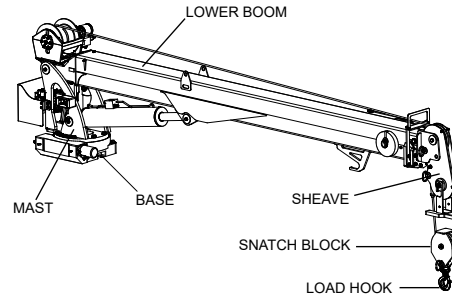

Figure 24

Rotation systems will vary depending on the crane model. Worm gear system is shown. Extension boom cylinders may be internally mounted, or externally mounted, depending on the crane model.



### 7.1.1 Decal Replacement Information

The following decals are found on your telescopic crane and warn of hazards related to the use of this equipment. Read and understand all decals before operating this equipment. If any decals on the equipment are not clearly readable, contact IMT Customer Service at 800-554-4421 or [www.imt.com](http://www.imt.com) to order replacements. Use only IMT replacement safety decals.



[www.imt.com/parts-service](http://www.imt.com/parts-service)

### 7.1.2 Identification Decal Parts List

Telescopic Crane Decal Parts, *Table 9*, contains part numbers for the individual safety decals that are shown on *Figure 25 & 26*. See chapter “12.0 Safety Decals” on *page 77* for a list of safety decal part numbers that are not shown on *Figure 25*.

TELESCOPIC CRANES			
No.	Part Number	Qty.	Comments
1.	95728993	1	DECAL KIT-COMMON 3300-6300
	95728994	1	DECAL KIT-COMMON 7600-12600
	95729117	1	DECAL KIT-COMMON 14000
2.	70391612	6	DECAL-GREASE WEEKLY (LEFT)
3.	70391613	2	DECAL-GREASE WEEKLY (RIGHT)
4.	70392399	1	DECAL-LUBRICATE WORM
5.	70392524	1	DECAL-ROTATE CRANE WHILE GREASING
6.	70395324	1	DECAL-ASME/ANSI B30.5-TELESCOPIC
7.	70399195	1	DECAL-DIAMOND IMT 4.00X8.00 (REFLECTIVE)
8.	70490167	1	DECAL-WARNING-PROP 65
9.	70490435	1	DECAL-CMD.CTRL LOGO
10.	71399136	1	DECAL-ANGLE IND RH SIII



TELESCOPIC CRANES			
No.	Part Number	Qty.	Comments
11.	71399137	1	DECAL-ANGLE IND LH SIII
12.	70490575	1	DECAL-LOAD BLOCK RATING 2.2 TONS 3300-4300
	70490576		DECAL-LOAD BLOCK RATING 4.3 TONS 5300-8600
	70490577		DECAL-LOAD BLOCK RATING 6.3 TONS 10600-12600
	71394082		DECAL-LOAD BLOCK RATING 7.0 TONS 14000

TELESCOPIC CRANES			
No.	Part Number	Qty.	Comments
13.	70490558	2	DECAL-ID 3300
	70490559	2	DECAL-ID 3300E
	70490560	2	DECAL-ID 4300
	70490561	2	DECAL-ID 4300E
	70490562	2	DECAL-ID 5300
	70490563	2	DECAL-ID 5300E
	70490564	2	DECAL-ID 6300
	70490565	2	DECAL-ID 6300E
	70490566	2	DECAL-ID 7600-27
	70490567	2	DECAL-ID 7600-32
	70490568	2	DECAL-ID 8600-27
	70490569	2	DECAL-ID 8600-32
	70490570	2	DECAL-ID 10600-27
	70490571	2	DECAL-ID 10600-32
	70490572	2	DECAL-ID 12600-27
	70490573	2	DECAL-ID 12600-32
70490632	2	DECAL-ID 14000-25	
70490633	2	DECAL-ID 14000-30	



Table 9

<b>TELESCOPIC CRANES</b>			
<b>No.</b>	<b>Part Number</b>	<b>Qty.</b>	<b>Comments</b>
14.	70490535	2	DECAL-CP 3300
	70490532	2	DECAL-CP 3300E
	70490536	2	DECAL-CP 4300
	70490537	2	DECAL-CP 4300E
	70490538	2	DECAL-CP 5300
	70490539	2	DECAL-CP 5300E
	70490540	2	DECAL-CP 6300
	70490541	2	DECAL-CP 6300E
	70490542	2	DECAL-CP 7600-27
	70490543	2	DECAL-CP 7600-32
	70490544	2	DECAL-CP 8600-27
	70490531	2	DECAL-CP 8600-32
	70490545	2	DECAL-CP 10600-27
	70490546	2	DECAL-CP 10600-32
	70490547	2	DECAL-CP 12600-27
	70490548	2	DECAL-CP 12600-32
70490637	2	DECAL-CP 14000-25	
70490638	2	DECAL-CP 14000-30	
15.	70029119	1	PLACARD-SERIAL NUMBER

7.1.3 Identification Decal Locations

HYDRAULIC

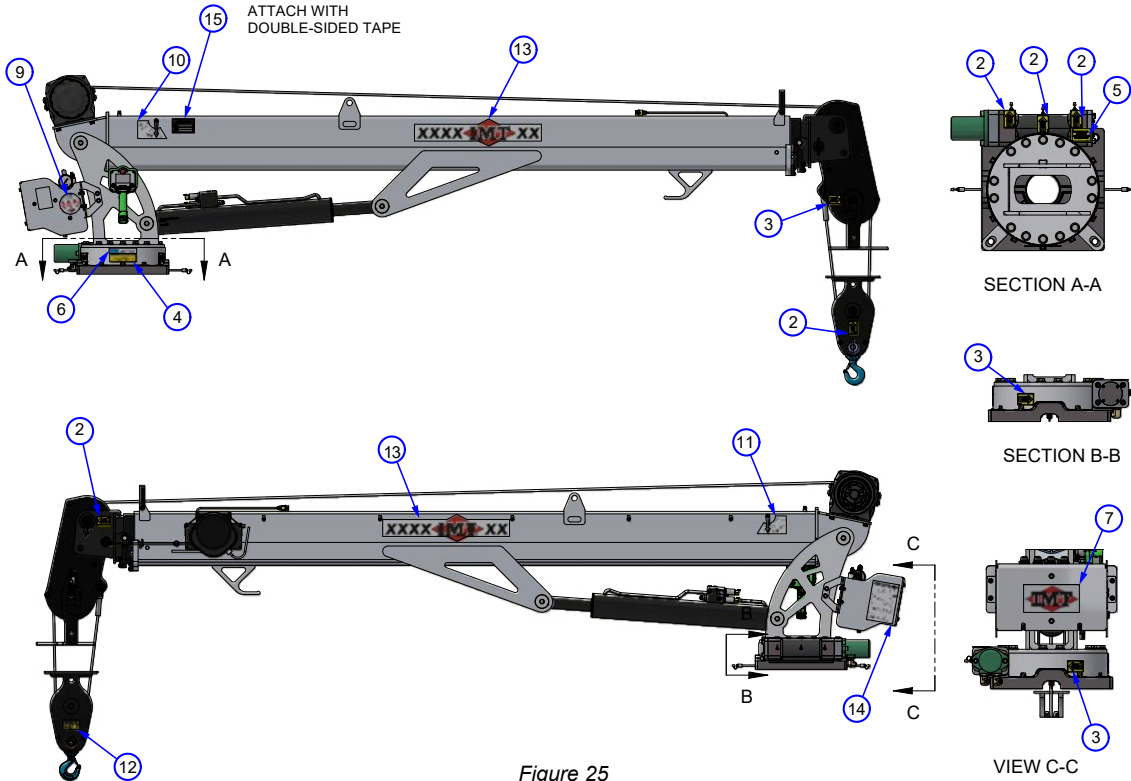

Figure 25

ELECTRIC

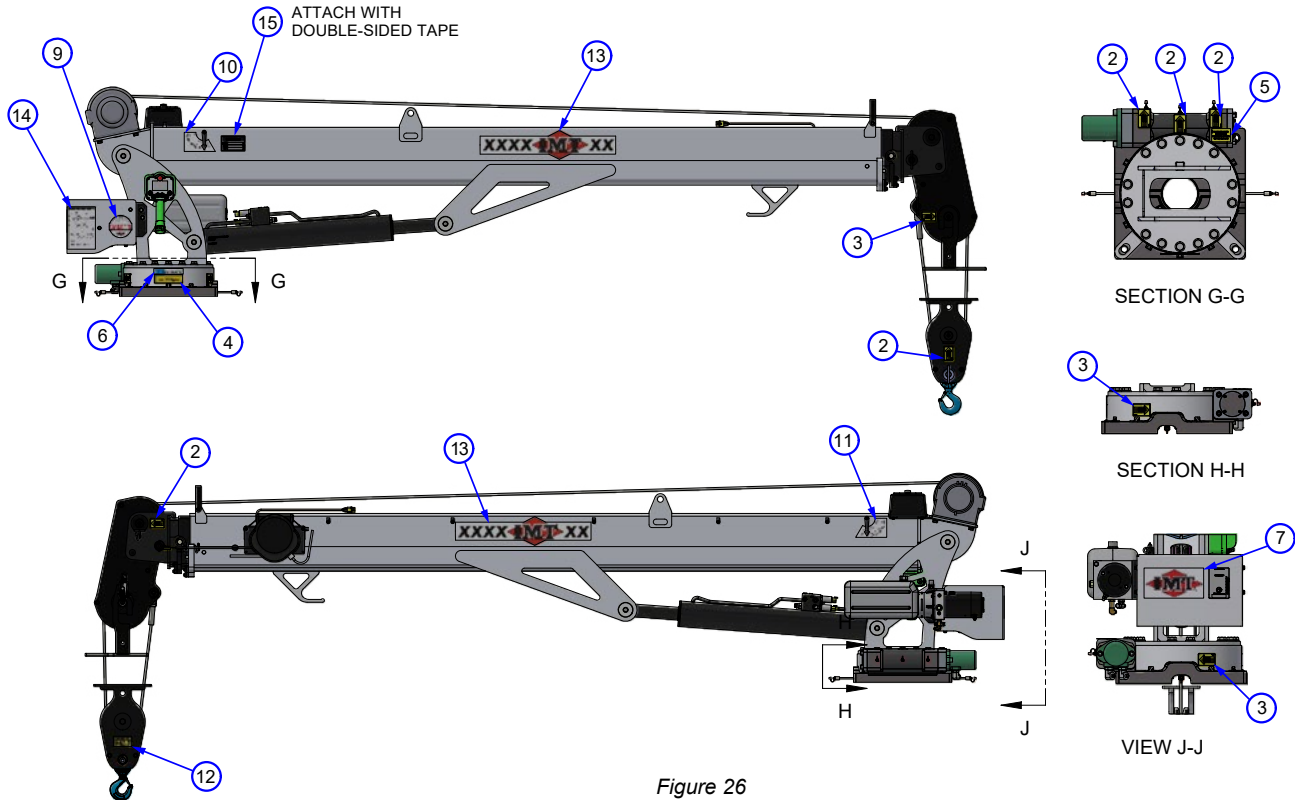

Figure 26

## 7.2 Hydraulic Pump

The hydraulic pump supplies hydraulic fluid under pressure to a directional control valve. The directional control valve is a four-way valve which regulates both the direction and rate of flow to the crane functions. If the hydraulic pump output should exceed the crane's system pressure setting while a load is being lifted, the pressure relief valve will open, venting any excess pressure directly back to the hydraulic reservoir assuring system protection.



**Hydraulic systems operate under very high pressure. Hydraulic fluid escaping from a pressurized system can penetrate unprotected body tissue. Never inspect for hydraulic leaks with bare hands or other exposed body parts. As a minimum, wear leather gloves and use cardboard or wood to inspect for leaks. If leaks are present, relieve pressure and allow system to cool prior to servicing. If injured by escaping hydraulic oil, contact a physician immediately. Serious complications may arise if not treated immediately.**

## 8.0 Wire Rope, Hitches, and Sling Loading Information

### 8.1 Wire Rope

OSHA requires regular inspections and permanent signed record-keeping on wire rope inspections. These inspections help the crane operator determine whether the rope can be safely used. Inspection criteria, including number and location of broken wires, wear, and elongation have been established by OSHA, ANSI, ASME and similar organizations.

#### 8.1.1 Wire Rope Inspection Criteria

1. INSPECTOR. The wire rope inspector must keep written reports of the rope condition on file at the work site, have the authority to order wire rope replacements and keep unsafe wire rope from being used.
2. PERIODS OF INSPECTION. Set up inspection periods for each material hoist wire rope. Determine inspection frequency by considering environment, degree of hazard to materials, frequency of operation, and the frequency with which the wire rope is subjected to its capacity limits. Inspect at least every 30 days.

3. **METHODS OF INSPECTION.** To inspect, unwind the working length of the wire rope from the hoist drum. Thoroughly inspect the rope sections that pass over sheaves, drums, or contacts saddles which make opposing turns. Inspect the rope close to the end attachments. **DO NOT** open the rope for inspection.
4. **IDLE EQUIPMENT.** Inspect wire rope on idle equipment prior to operation.

When a wire rope has been removed from service, it must not be re-used on another application.

Every wire rope user should understand that each type of fitting attached to a wire rope has a specific efficiency rating which can reduce the working load of the rope assembly or rope system. This must be given due consideration in determining the capacity of a wire rope system.

### 8.1.2 Wire Rope Lubrication

Wire rope used on IMT cranes does not have continuous lubrication. Use open gear lubricant to protect the wire rope on the crane. The areas of rope which experience the most wear are located over sheaves. This area requires the most rope lubrication.

### 8.1.3 Basic Hitches

**VERTICAL** or straight attachment is simply the use of a sling to connect a lifting hook to the load. A tagline should be used on such a lift to prevent rotation which can damage the sling.

**CHOKER HITCHES** reduce lifting capability of a sling. Since this method of rigging affects the ability of the wire rope components. To adjust during the lift, place angular loading on the body of the sling and create a small diameter bend in the sling body at the choke point.

**BASKET HITCHES** distribute a load equally between the two legs of a sling within limitations imposed by the angles at which legs are rigged to the load.

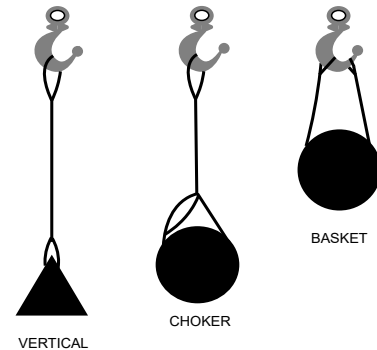

Figure 27

### 8.1.4 Sling Loading

Sling angle of loading is the angle measured between a horizontal line and the sling leg or body. This angle is very important and can have a dramatic effect on the rated load of the sling. When this angle decreases, the load on each leg increases. This principle applies whether the sling is used with legs at an angle in a basket hitch, or multi-leg bridle slings. Horizontal sling angles of less than 30° shall not be used.

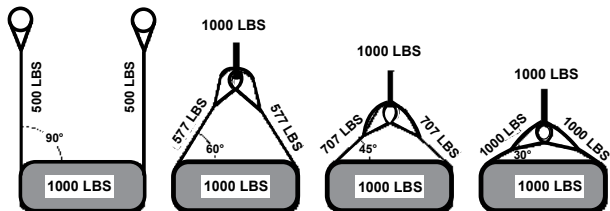

Figure 28

### 8.1.5 Wire Rope Lay

Wire rope “lay” indicates the directions strands lay in the rope—right or left. When you look down a rope, strands of a right lay rope go away from you to the right, like a right-hand screw thread. Left lay is the opposite and corresponds to a left-hand screw thread.

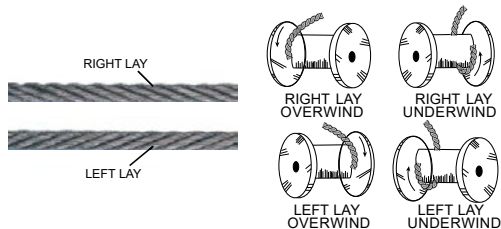

Figure 29

**NOTE:** You must choose the correct lay for your winch drum to avoid winch spooling problems and rope which does not lay correctly. Use the graphics to help in selecting the correct wire rope based on the direction of drum winding.

### 8.1.6 Wedge Socket Attachment

When attaching a wedge socket, see one of the approved methods displayed in “8.1.7 Cable Thimble Attachment” on page 46

### 8.1.7 Cable Thimble Attachment

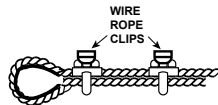

Figure 30

When attaching a cable thimble to a winch wire rope,

proceed as follows:

**Note:** The base of the clip is applied to the live end of the rope and the U-Bolt is applied to the dead end.

1. Attach the first clip so the U-Bolt is no less than the clip base width from the dead end of the rope.
2. Attach the second clip as near the loop as possible.

Wire Rope Diameter (Inches)	Min. # Of Clips	Amt Of Rope To Turn Back (Inches)	Space Between Clips (Inches)	Torque (ft-lbs)
1/4"	2	4-3/4"	3-1/4"	15
5/16"	2	5-1/4"	3-1/4"	30

Table 10

### 8.1.8 Wire Rope Attachments

Three types of rope attachments:

1. Loop back method.
2. Extra rope clipped to main rope.
3. Securing dead end.

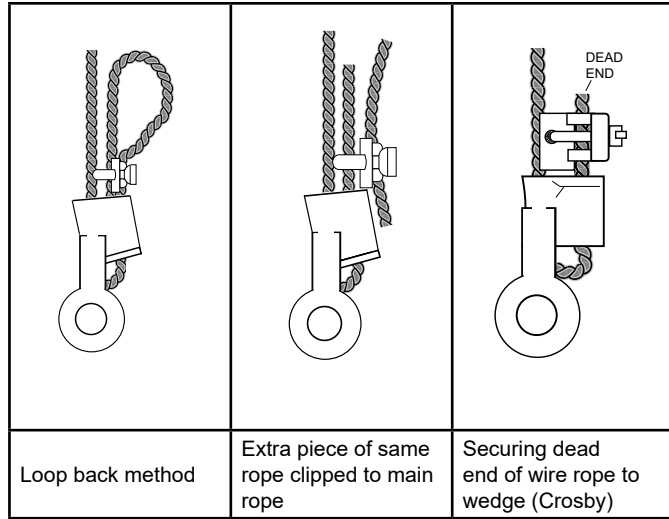

Figure 31

### Wire Rope Lubrication

Lubricate the wire rope using ChainMate™ chain and wire rope lubricant, Vitalife® 400, or equivalent. To lubricate the rope:

1. Clean dirt, dust, and foreign matter from the rope.
2. Apply ChainMate™ lubricant or equivalent penetrating the strands of the rope. Apply according to the lubricant specifications.

- Apply lubricant heavily to portions which encounter bending such as at the sheave and winch.

## 8.1.9 Wire Rope Maintenance

### **WARNING**

If the daily wire rope inspection shows a problem with the wire rope, the rope must be repaired or replaced. Use only original wire rope from IMT. Failure to do so may cause problems with the anti-two block system. See when to replace wire rope chart. (Table 11)

## 8.1.10 When To Replace Wire Rope

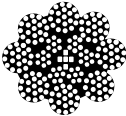
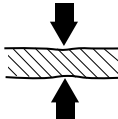
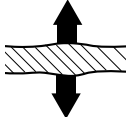
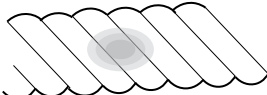
<p>When there are three broken wires in one strand, or a total of six broken wires in all strands in any one-rope lay.</p>	
<p>When the flat spots on the outer wires appear and those outside wires are less than 2/3 the thickness of the unworn outer wire.</p>	
<p>When there is a decrease of diameter indicating a core failure.</p>	
<p>When kinking, crushing, birdcaging, or distortions occur.</p>	
<p>When there is noticeable heat damage (discoloration) of the rope by any means.</p>	

<p>When the diameter is reduced from nominal size by 1/32" or more.</p>	
<p>If a broken wire protrudes or loops out from the core of the rope.</p>	

Table 11

## 8.1.11 Hooks

Hook swivels prevent a load from twisting caused by a natural tendency for wire rope to unwind under load. These swivels, usually part of the hook, are fitted with bearings to provide for rotation.

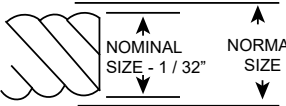
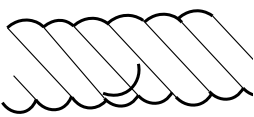
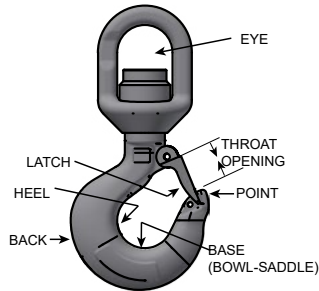

Figure 32

## 8.1.12 Hook Precautions

- DO NOT attempt lifting a load which is larger than the load rating of the hook.
- NEVER use a hook's yield point as an indicator of its capacity.
- DO NOT use a hook to lift personnel. IMT prohibits the transport of personnel on any load.
- READ AND UNDERSTAND all information, maintenance instructions, and safety warnings which accompany the hook and related rope attachments.
- KNOW THE RATED LOAD of the hook in use. This information may be attached to the hook, if not, contact the manufacturer.
- CONTACT the hook manufacturer if in doubt about a hook's serviceability.
- USE HOOKS DESIGNED for your particular application (salt water exposure, etc.).
- NEVER weld attachments to a finished hook in field applications. The heat from the welding process will alter and destroy the design properties of the hook material.
- CENTER THE LOAD in the base (bowl saddle) of the hook to prevent applying load to the point.



- AVOID shock loading.
- DO NOT apply side loads on a hook.
- DO NOT apply back loads on a hook.
- DO NOT apply loads of any nature on a latch device.
- DO NOT place hands, fingers, or body between a hook and the load.
- INSPECT regularly for excessive wear and maintain the hook in safe operating condition. If not qualified, arrange for testing and analysis of the hook with the manufacturer or qualified repair technician.
- WORN components do not provide the same safe working limits as a new hook.
- PAINTED HOOKS if suspected of defects, should be stripped of paint before inspection.
- DO NOT paint over nameplates, warning decals, or placards.
- REPLACE any missing placards which may have been a part of the hood by contacting the manufacturer for replacement.
- CHECK wedge sockets after a jolt or impact for a dislodged wedge.

### **8.1.13 Hook Inspection**

Inspection should be done by a qualified person following manufacturer's recommendations. When the inspection requirements for hooks are specified in regulations applicable to your equipment, those regulations will take precedence over the information presented here.

### **8.1.14 New and Repaired Hooks**

Prior to initial use, all new and repaired hooks shall be inspected to assure compliance with the items listed in "8.1.13 Hook Inspection" on page 50.

### **8.1.15 Hook Testing**

Hooks should be tested at least once a year by magnafluxing, X-ray, or other qualified method. Intermittent tests can be conducted by the readily available (though less accurate) oil stain method:

1. Immerse hook into lube oil.
2. Wipe hook dry.
3. White-wash hook surface.
4. Inspect hook for see page of white-wash into fractures.

**8.1.16 Hooks In / Not In Regular Use**

Inspection of hooks in regular use are to be performed in two methods: **FREQUENT** and **PERIODIC**, as described in Section 8.1.18 (*Table 13*). Hooks not in regular use should be inspected before they are returned to service.

**NOTE:** Hooks having any of the listed deficiencies shall be removed from service unless a qualified person approves their continued use and initiates corrective action. Hooks approved for continued use shall be subjected to periodic inspection.

**8.1.17 Reasons To Remove Hook From Service**

CHECK FOR:	REASON TO REMOVE HOOK FROM SERVICE
<b>DISTORTION</b>	A Bend or twist exceeding 10° from the plane of the unbent hook.
<b>HOOK LATCH MISSING</b>	<b>HOOK WITHOUT LATCH:</b> An increase in throat opening exceeding 15%. (or as recommended by the manufacturer)
<b>WEAR</b>	If wear exceeds 10% of the original sectional dimension. (Or as recommended by the manufacturer)

CHECK FOR:	REASON TO REMOVE HOOK FROM SERVICE
<b>CRACKS, NICKS, GOUGES</b>	Repair of cracks, nicks, and gouges shall be carried out by a designated person by grinding longitudinally, following the contour of the hook, provided that no dimension is reduced more than 10% of its original value. (Or as recommended by the manufacturer)
<b>LATCH</b>	If a latch becomes inoperative because of wear or deformation, and is required for the service involved, it shall be replaced or repaired before the hook is put back into service. If the latch fails to fully close the throat opening, the hook shall be removed from service until repairs are made.
<b>HOOK ATTACHMENTS &amp; SECURING MEANS</b>	If any indication of distortion, wear, cracks, nicks, or gouges are present . (Unless a qualified person authorizes their use, or as recommended by the manufacturer)

*Table 12*



8.1.18 Hook Inspection Checklist

	FREQUENT INSPECTIONS	PERIODIC INSPECTIONS
<b>MEANS</b>	Visual examination by the operator or designated person.	Visual inspections by an appointed person.
<b>RECORDS</b>	Records of the inspection are not required.	Records of apparent external hook conditions are to be made to provide the basis for continuing hook evaluation.
<b>NORMAL SERVICE</b> Less than 85% of rated load except for isolated instances.	Monthly	Yearly
<b>HEAVY SERVICE</b> 85% to 100% of rated load on a regular basis.	Weekly to Monthly	Yearly - unless hook conditions indicate a need for detailed inspection.

	FREQUENT INSPECTIONS	PERIODIC INSPECTIONS
<b>SEVERE SERVICE</b> 85% to 100% of rated load regularly and under environmental conditions unfavorable, harmful, or detrimental to the hook.	Daily to Weekly	Quarterly - As above unless detailed inspection shows a need for non-destructive testing.
<b>SPECIAL OR INFREQUENT SERVICE</b>	As authorized by a qualified person and before the first period of service and as directed by the qualified person for any subsequent operation.	As authorized by a qualified person and before the first period of service and as directed by the qualified person for any subsequent operation.

Table 13

## 9.0 Pre-operation Inspection

**DAILY (D):** Before each shift of operation, those items designated with a (D) must be inspected.

**MONTHLY (M):** Monthly inspections or 100 hours of normal operation (whichever comes first) includes all daily inspections plus items designated with an (M). This inspection must be recorded and retained for a minimum of 3 months.

**QUARTERLY (Q):** Every 3 months or 300 hours of normal operation (whichever comes first) includes all daily and monthly inspection items plus items designated with a (Q). This inspection must be documented, maintained, and retained for a minimum of 12 months by the employer that conducts the inspection.

**ANNUAL (A):** Each year or 1200 hours of normal operation (whichever comes first) includes all items on this form which encompasses daily, monthly and quarterly inspections plus those items designated by (A). This inspection must be documented, maintained, and retained for a minimum of 12 months, by the employer that conducts the inspection.

## 9.1 Pre-Operation Correction

**S** = Satisfactory

**R** = Recommendation (Should be considered for corrective actions)

**NA** = Not Applicable

**X** = Deficient (Note: If a deficiency is found, an immediate determination must be made as to whether the deficiency constitutes a safety hazard and must be corrected prior to operation.)

Freq.	Key	Insp. Description	Status
D	Labels	All load charts, safety & warning labels, & control labels are present and legible.	
D	Crane	Check all safety devices for proper operation.	
D	Controls	Control mechanisms for proper operation of all functions, leaks & cracks.	
D	Station	Control and operator's station for dirt, contamination by lubricants, & foreign materials.	
D	Hyd. System	Hydraulic system (hoses, tubes & fittings) for leakage & proper oil level.	



Freq.	Key	Insp. Description	Status
D	Hook	Presence & proper operation of hook safety latches.	
D	Wire Rope	Inspect for apparent deficiencies per applicable requirements and manufacturer's specifications.	
D	Pins	Proper engagement of all connecting pins & pin retaining devices.	
D	General Covers	Overall observation of crane for damaged or missing parts, cracked welds & presence of safety.	
D	Operation	During operation, observe crane for abnormal performance, unusual wear (loose pins, wire rope damage, etc.). If observed, discontinue use & determine cause & severity of hazard.	
D	Remote Control	Operate remote control devices to check for proper operation.	

Freq.	Key	Insp. Description	Status
D	Elec.	Operate all lights, alarms, etc. to check for proper operation.	
D	Anti-two block or Two-block damage prev.	Operate anti-two-blocking or two-block prevention devices to check for proper operation.	
M	Valves	Control valve linkages for wear, smoothness of operation & tightness of fasteners. Relief valve for proper pressure settings.	
M	General	Bent, broken or significantly rusted corroded parts.	
M	Electrical	Electrical apparatus for malfunctioning, signs of apparent excess deterioration, dirt or moisture accumulation. Electrical systems for presence of dirt, moisture and frayed wires.	



Freq.	Key	Insp. Description	Status
M	Structure	All structural members for damage.	
M	Welds	All welds for breaks & cracks.	
M	Pins	All pins for proper installation & condition.	
M	Hrdw.	All bolts, fasteners & retaining rings for tightness, wear & corrosion.	
M	Wear Pads	Condition of wear pads.	
M	Pump & Motor	Hydraulic pumps & motors for leakage at fittings, seals, and between sections. Check tightness of mounting bolts.	
M	PTO	Transmission / PTO for leakage, abnormal vibration, noise, alignment & mounting bolt torque.	
M	Hyd. Fluid	Quality of hydraulic fluid and for presence of water.	

Freq.	Key	Insp. Description	Status
M	Hyd. Lines	Hoses & tubes for leakage, abrasion damage, blistering, cracking, deterioration, fitting leakage & secured properly.	
M	Hook	Load hook for abnormal throat distance, twist, wear & cracks.	
M	Wire Rope	Condition of load line.	
M	Manual	Presence of operator's manuals with unit.	
M	Manual	Other	
Q	Daily	All daily inspection items.	
Q	Monthly	All monthly inspection items.	
Q	Rotation System	Rotation bearing for proper torque of all mounting bolts.	
Q	Hrdw.	Base mounting bolts for proper torque.	

# Maintenance



Freq.	Key	Insp. Description	Status
Q	Structure	All structural members for deformation, cracks & corrosion.	
Q	Structure	Base.	
		Stabilizer Beams & Legs.	
		Mast.	
		Inner Boom.	
		Outer Boom.	
Q	Hrdw.	Pins, bearings, shafts, gears, rollers, & locking devices for wear, cracks, corrosion & distortion.	
		Rotation bearing(s).	
		Inner boom pivot pin(s) & retainer(s).	
Q	Hrdw.	Outer boom pivot pin(s) & retainer(s).	
		Lift cylinder pin(s) & retainer(s).	
		Extension cylinder pin(s) & retainer(s).	

Freq.	Key	Insp. Description	Status
Q	Hrdw.	Boom tip attachments.	
Q	Hyd. Lines	Hoses, fittings & tubing for proper routing, leakage, blistering, deformation & excessive abrasion.	
		Pressure line(s) from pump to control valve.	
Q	Hyd. Lines	Return line(s) from control valve to reservoir.	
		Suction line(s) from reservoir to pump.	
		Pressure line(s) from control valve to each function.	
		Load holding valve pipe(s) and hose(s).	
		Other.	



Freq.	Key	Insp. Description	Status
Q	Pumps & Motors	Pumps & motors for loose bolts / fasteners, leaks, noise, vibration, loss of performance, heating & excess pressure.	
		Winch motor(s).	
		Rotation motor(s).	
		Other.	
Q	Valves	Hydraulic valves for cracks, spool return to neutral, sticking spools, proper relief valve setting, relief valve failure.	
		Main control valve.	
		Load holding valve(s).	
		Stabilizer or auxiliary control valve(s).	
		Other.	
Q	Valves	Other.	

Freq.	Key	Insp. Description	Status
Q	Cylinder	Hydraulic cylinders for drifting, rod seal leakage & leakage at welds. Rods for nicks, scores & dents. Case for damage. Case & rod ends for damage & abnormal wear.	
		Stabilizer cylinder(s).	
		Inner boom cylinder(s).	
		Outer boom cylinder(s).	
		Extension cylinder(s).	
Q	Cylinder	Rotation cylinder(s)	
		Jib lift cylinder(s)	
		Jib extension cylinder(s)	
		Other	
Q	Winch	Winch, sheaves & drums for damage, abnormal wear, abrasions & other irregularities.	
A	Hyd. Filters	Hydraulic filters for replacement per maintenance schedule.	

## Maintenance



Freq.	Key	Insp. Description	Status
A	Daily	All daily inspection items.	
A	Monthly	All monthly inspection items.	
A	Qrtly.	All quarterly inspection items.	
A	Hyd. System	Hydraulic fluid change per maintenance schedule.	
A	Controls	Control valve calibration for correct pressures & relief valve settings.	
A	Valves	Safety valve calibration for correct pressures & relief valve settings.	
A	Valves	Valves for failure to maintain correct settings.	
A	Rotation System	Rotation drive system for proper backlash clearance & abnormal wear, deformation & cracks.	
A	Lube	Gear oil change in rotation drive system per maintenance schedule.	

Freq.	Key	Insp. Description	Status
A	Hrdw.	Check tightness of all fasteners and bolts.	
A	Loadline	Loadline for proper attachment to drum.	

Table 14



	3300E	3300H	4300E	4300H	5300E	5300H	6300E	6300H	7600-27	7600-32	8600-27	8600-32	10600-27	10600-32	12600-27	12600-32	14000-25	14000-30
Flow (GPM)	1.38	6	1.38	6	1.38	8	1.38	8	10	10	10	10	12	12	12	12	10	10
Operating Pressure (psi)	2150	2150	2450	2450	2300	2300	2750	2750	2400	2425	2720	2575	2275	2375	2800	2650	3200	3200
Stability Test Angle at Full Extension	30°	30°	30°	30°	30°	30°	30°	30°	30°	30°	30°	30°	30°	30°	30°	30°	0°	0°
Rated Full Extension Load (lb) at Stability Test Angle	1350	1350	1560	1560	1820	1820	2560	2560	2260	1700	2600	2000	3700	3070	4524	3576	3630	2600
Stability Test Load (lb)	1593	1593	1841	1841	2148	2148	3021	3021	2667	2006	3068	2360	4366	3623	5339	4219	3068	4283

Table 15

# 10.0 Quick Guides CMD.CTRL™ Base Unit

## 10.1.1 Navigation—Continued

### 10.1 Navigation

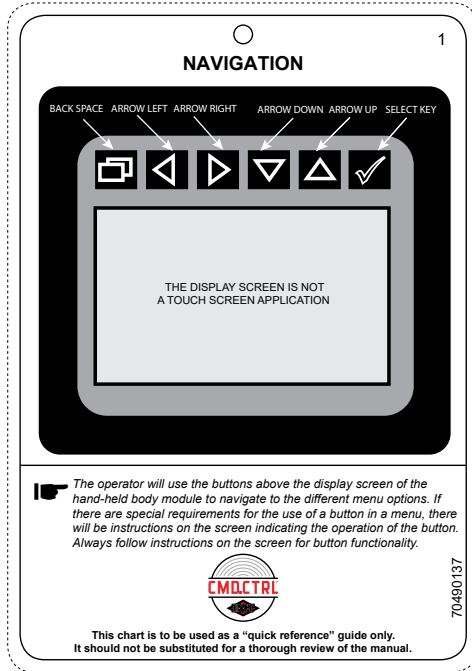

Figure 27

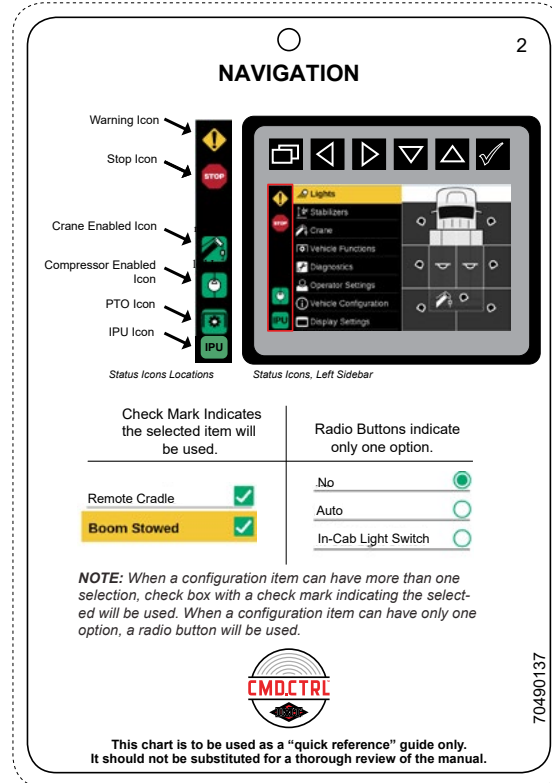

Figure 28

## 10.2 Lights

3

### LIGHTS

The Lighting Screen is split into two areas:

- Light Group (left sidebar).
- Status and Individual Selection (right sidebar).

From the Main Menu:

1. Press to select Lights Mode.
2. Press to select individual light group.

Press to choose light(s).

When selecting a specific light, the illustration will turn green

*Main Menu Lights Preview*

*Left sidebar Light Group*      *Right sidebar Status and Individual Selection*

Front Left / Right Flood Lights  
Compartment Lights  
Front  
Rear  
Left  
Right  
Boom Tip Lights

*Light Menu*

3. Press to turn power ON or power OFF selected light groups or individual lights.
4. Press to return to Main Screen.

Your display screen will only show the lights that are configured for your vehicle.

70490137

This chart is to be used as a "quick reference" guide only. It should not be substituted for a thorough review of the manual.

Figure 29

## 10.3 PTO

4

### OPERATING SETTINGS - PTO

1. From the **Main Menu** > **Operator Settings** > **Truck Settings**.
2. Press to navigate to PTO Activation.
3. Press to select **PTO Activation** states.  
None: Operator DOES NOT want the PTO to come on automatically.  
**Auto**: Functionality is set to come on automatically when requiring PTO power.  
In Cab Multi-Switch: The PTO power is engaged from the switch on the dash, or through one of the other menus.
4. Press to select a specific PTO Activation state.
5. Press to return to **Main Menu**

If the operator chooses **None**, PTO power must be activated manually through the switch on the dash, or through one of the other menus.

### VEHICLE FUNCTIONS - AUTO PTO

1. From the **Main Menu** press the to navigate to **Vehicle Functions**.
2. Press to navigate to **PTO**.
3. Press to power **ON** or power **OFF** PTO function.
4. Press to return to **Main Menu**

If the chassis type is set to "IPU" or "Paccar Engine", the Crane Power and PTO will not be shown.  
Auto PTO has no user interaction, and most will be configured for Auto PTO before it leaves the factory.

70490137

This chart is to be used as a "quick reference" guide only. It should not be substituted for a thorough review of the manual.

Figure 30

## 10.4 Engine Start / Stop

5

1. Press to select **Vehicle Functions** mode.
2. Use to navigate to **Start** or **Stop Engine** mode.
3. Press and hold until you hear the engine **START** or **STOP**.
4. Press to return to the **Main Menu**.

Pressing and holding the works the same as a key turning on or turning off the engine on a vehicle. Pressing and holding the will shut-off the engine in the Engine Stop function.

The illustration above shows the Engine Start mode.  
The instructions are for both Engine Start and Engine Stop.

This chart is to be used as a “quick reference” guide only.  
It should not be substituted for a thorough review of the manual.

70490137

Figure 31

## 10.5 Compressors

6

1. From the **Main Menu** press to navigate to **Vehicle Functions**.
2. Press to select **Vehicle Functions**.
3. Press to navigate to **Compressor**.
4. Press to activate or deactivate **Compressor**.
5. Press to return to **Main Menu**.

This chart is to be used as a “quick reference” guide only.  
It should not be substituted for a thorough review of the manual.

70490137

Figure 32

## 10.6 Crane

7

### CRANE

**Main Menu: Crane**  
The Crane menu allows the selection of Power On and Power Off options for Crane, PTO, and Boom Tip Lights.

**Crane: Enable Mode**

*If the chassis type is set to "IPU" the Crane Power and PTO will not be shown. Instead, the IPU Status option will be shown with instructions on how to enable the IPU. If the Chassis Option is selected as Paccar Engine, the PTO object also will not be shown.*

*After the IPU activation, the operator can remove the key from the ignition.*

**IPU Status Row**

When Crane is selected to turn on, a pop-up menu will be displayed asking the operator to confirm the stabilizers have been deployed. Once you confirm the stabilizers are deployed, the display will verify the status of the PTO.

*If a menu option is not configured it will not be displayed on the screen. If none of the options are configured to your equipment, "No Options Configured," will be displayed.*

**Crane: Stabilizer Acknowledgment**

70490137

This chart is to be used as a "quick reference" guide only. It should not be substituted for a thorough review of the manual.

Figure 33

## 10.7 Stabilizers

8

### STABILIZERS

The Stabilizer menu allows the operator to maneuver selected stabilizers from the control screen in a two-step process.

- Press to select Stabilizer Mode.  
Press to initiate Stabilizer states.
- Press to initiate Stabilizer.
- Press to operate the Stabilizer selected.
- Once the requested stabilizer is highlighted, press to enter the stabilizer control mode to move the stabilizer up and down or extend the stabilizers back and forth. The requested stabilizer's active movement is highlighted.
- Press to return to Stabilizer or Main Menu.

**Main Menu: Stabilizer Preview**

**Stabilizer Selection Mode**

**Stabilizer: Control Mode**

70490137

This chart is to be used as a "quick reference" guide only. It should not be substituted for a thorough review of the manual.

Figure 34

## 10.8 Fault Codes

9

### FAULT CODES

1. Press to navigate to the **Diagnostic** menu.
2. Press to select the **Diagnostic** menu.
3. Press to navigate to **Fault Codes**.
4. Press to select the **Fault Code** preview menu.
5. Press to view up to 25 fault states:
  - 25 most recent codes in chronological order
  - DTCØ indicates a power cycle.
  - Press and hold to clear fault log.

This chart is to be used as a "quick reference" guide only. It should not be substituted for a thorough review of the manual.

70490137

Figure 35

## 10.9 Intergrated Power Unit IPU

10

### INTEGRATED POWER UNIT (IPU) ACTIVATION

**NOTE: PTO ICON WILL NOT DISPLAY IN AN IPU CONFIGURATION.**

When the IPU Chassis is selected, the IPU will be used to drive the hydraulic power for the crane and body functions, and will command hydraulic power when needed for the Crane, Stabilizers, and Compressor.

To start IPU:

1. Engage E-Brake.
2. Turn chassis ignition key to the "RUN" position.
3. Activate cab switch # 2.
4. Wait two seconds.
5. Chassis ignition can be turned from the "RUN" position, to the "OFF" position. Ignition key can be removed.
6. Navigate to Crane Menu and turn on the crane.
7. IPU will be operational using the controls found in their stored compartment.

This chart is to be used as a "quick reference" guide only. It should not be substituted for a thorough review of the manual.

70490137

Figure 36

# 11.0 Quick Guides CMD.CTRL™ Radio Remote

# 11.2 Toggle Identification

## 11.1 Face Plate Identification

1

### FACE PLATE IDENTIFICATION

DISPLAY		
ITEM NO.	NAME	DESCRIPTION
1.	Top Bar Area	Displays: Battery Status, Operation Mode, Received Signal strengths
2.	Indicator Area	System Feedback
3.	Soft Toggle Area	Displays: Soft Toggle Icons

**NOTE:** The lines separating the different segments of the display are for visual reference only, and will not be visible during the operation of the remote.

This chart is to be used as a "quick reference" guide only. It should not be substituted for a thorough review of the manual.

70490366

Figure 37

2

### TOGGLE IDENTIFICATION

TOGGLE NAME	DESCRIPTION
Right Fixed Function Up	A hard function toggle, meaning its operation never changes. • Turning the remote <b>ON/OFF</b> - toggle upward and <b>HOLD</b> for 1/2 second.
Right Fixed Function Down	A hard function toggle, meaning its operation never changes. • Horn - toggle <b>DOWN</b> and <b>HOLD</b> until you hear the horn • Switching Operation Screens - short clicks downward will display next screen in sequence: • Crane • Lights • Stabilizers • Operations
Soft Toggles 1 – 4	Functions will change based on the screens that are being displayed.
Left Fixed Function Up	A hard function toggle, meaning its operation never changes. • Short click <b>UP</b> to enable / disable compressor.
Left Fixed Function Down	A hard function toggle, meaning its operation never changes. • Short click <b>DOWN</b> to change speed
Emergency Stop	Pressing <b>DOWN</b> will shut down the chassis engine in an emergency, pull to release
Trigger	Controls crane movement speed.

This chart is to be used as a "quick reference" guide only. It should not be substituted for a thorough review of the manual.

70490366

Figure 38

### 11.3 Top Bar Icons

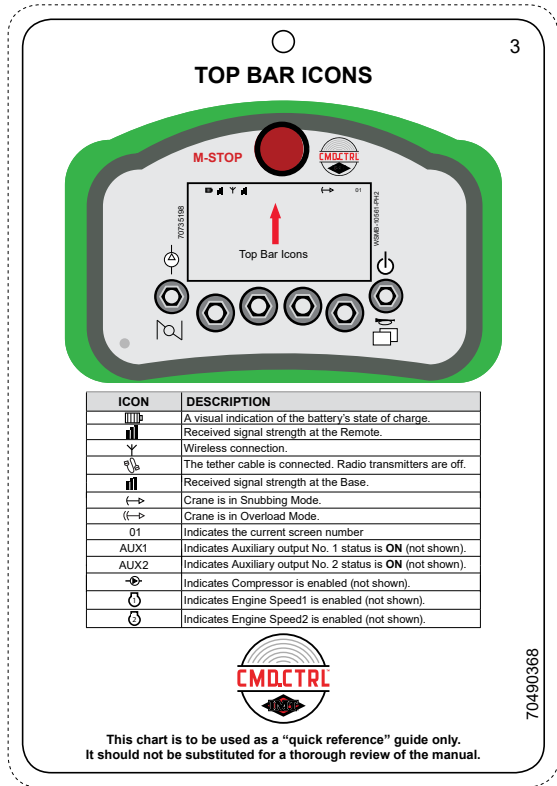

Figure 39

### 11.4 Fixed Function Icons

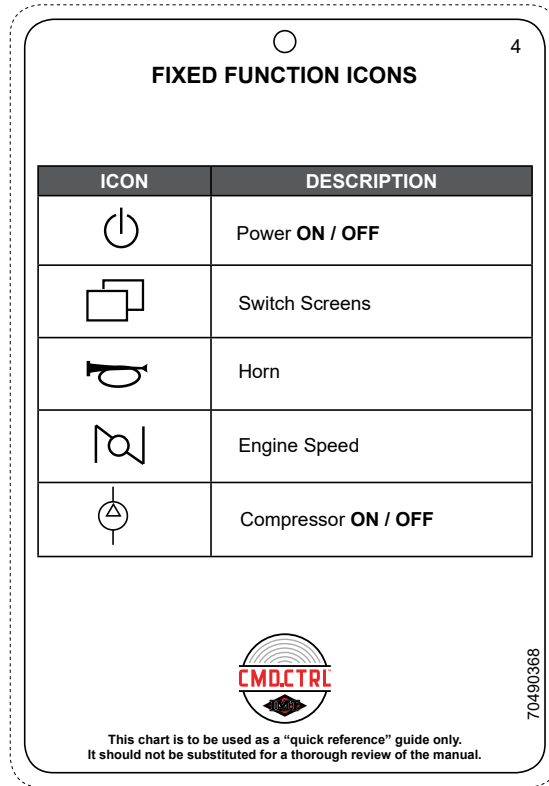

Figure 40

## 11.5 Crane Operations

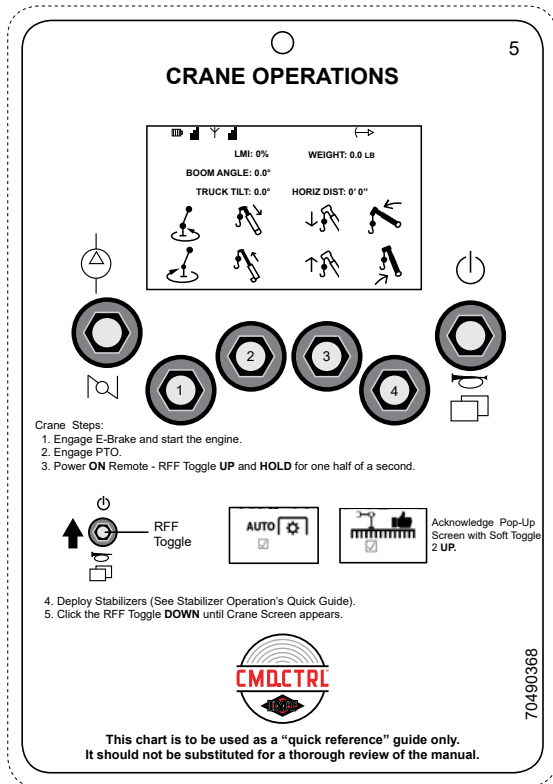

Figure 41

## 11.6 Light Operations

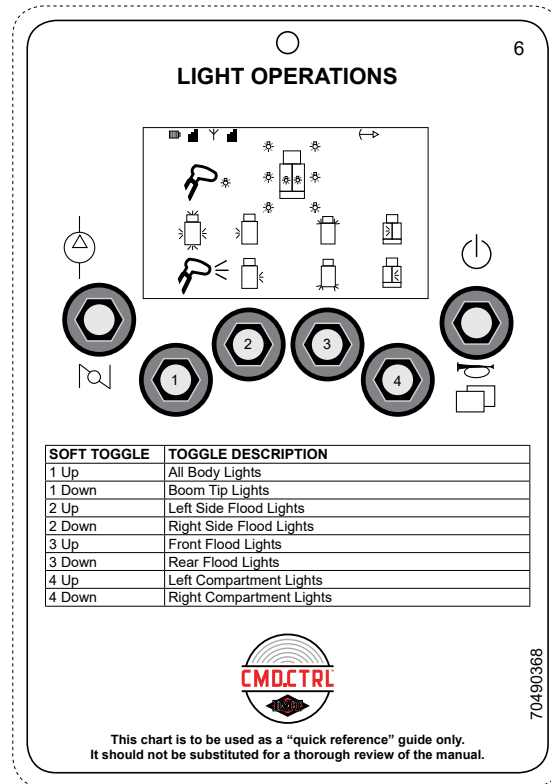

Figure 42

## 11.7 Stabilizer Operations

**STABILIZER OPERATIONS** 7

Stabilizer Steps:

- Engage E-Brake and start the engine.
- Engage PTO.
- Power ON Remote - RFF Toggle **UP** and **HOLD** for one half of a second.

↑ RFF Toggle

- Click the RFF toggle **DOWN** until stabilizer screen appears.

↓ RFF Toggle

**AUTO**

When Auto PTO is configured, the Pop Up can be acknowledged with Soft Toggle 2 **UP**.

- Select the desired stabilizer function using the Soft Toggles to operate the individual stabilizers.

This is an example. Actual stabilizer screen and functions will depend on stabilizer configuration.

This chart is to be used as a "quick reference" guide only. It should not be substituted for a thorough review of the manual.

70490368

Figure 43

## 11.8 Operations

**OPERATIONS** 8

ITEM	DESCRIPTION
Soft Toggle 1	Toggle <b>UP</b> : Engine <b>START</b> . Toggle <b>DOWN</b> : Engine <b>STOP</b> .
Soft Toggle 2	Toggle <b>UP</b> : Auxiliary 1 <b>ON/OFF</b> . Toggle <b>DOWN</b> : Auxiliary 2 <b>ON/OFF</b> .
Soft Toggle 3	Toggle <b>DOWN</b> : PTO - Engage / Disengage
Soft Toggle 4	Toggle <b>UP</b> Toggle <b>DOWN</b> : Accesses the Menu.

This chart is to be used as a "quick reference" guide only. It should not be substituted for a thorough review of the manual.

70490368

Figure 44

## 11.9 Compressor

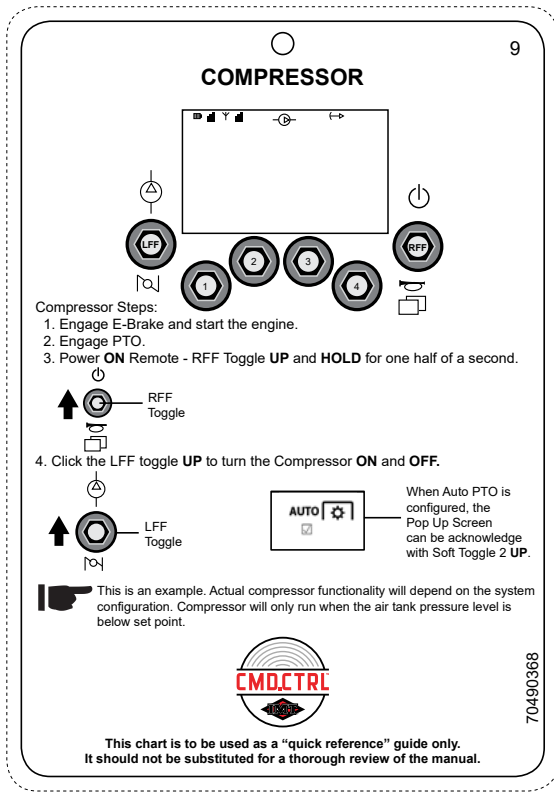

Figure 45

## 11.10 Crane Icons

10

### CRANE ICONS

ICON	DESCRIPTION
	Boom Rotate CCW
	Boom Rotate CW
	Boom Retract
	Boom Extend
	Winch Out
	Winch In
	Boom Down
	Boom Up

70490368

This chart is to be used as a "quick reference" guide only. It should not be substituted for a thorough review of the manual.

Figure 46

## 11.11 Light Icons

LIGHT ICONS	
ICON	DESCRIPTION
	Body Light Indicator
	Boom Tip Light Indicator
	Boom Tip Lights
	Front Flood Lights
	Rear Flood Lights
	Left Flood Lights
	Right Flood Lights

This chart is to be used as a "quick reference" guide only. It should not be substituted for a thorough review of the manual.

Figure 47

## 11.11.1 Light Icons—Continued

LIGHT ICONS - CONTINUED	
ICON	DESCRIPTION
	Left Compartment Lights
	Right Compartment Lights

This chart is to be used as a "quick reference" guide only. It should not be substituted for a thorough review of the manual.

Figure 48

### 11.12 Operation Icons

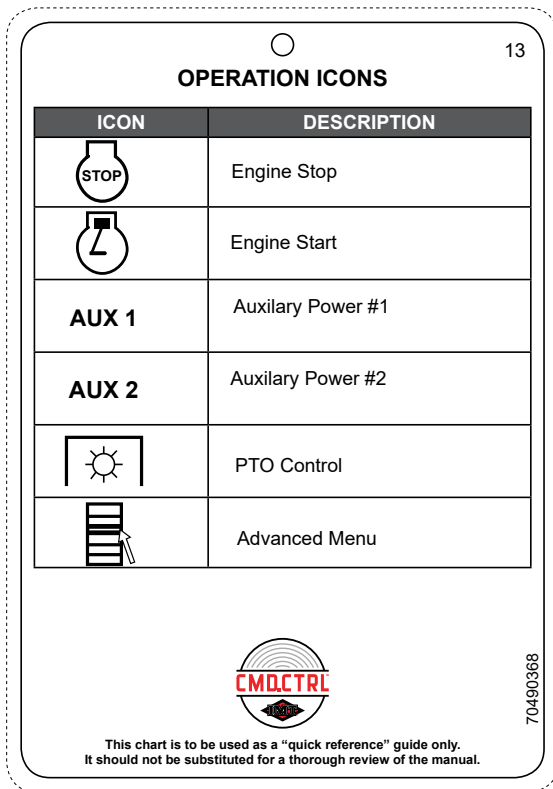

Figure 49

### 11.13 Stabilizer Icons

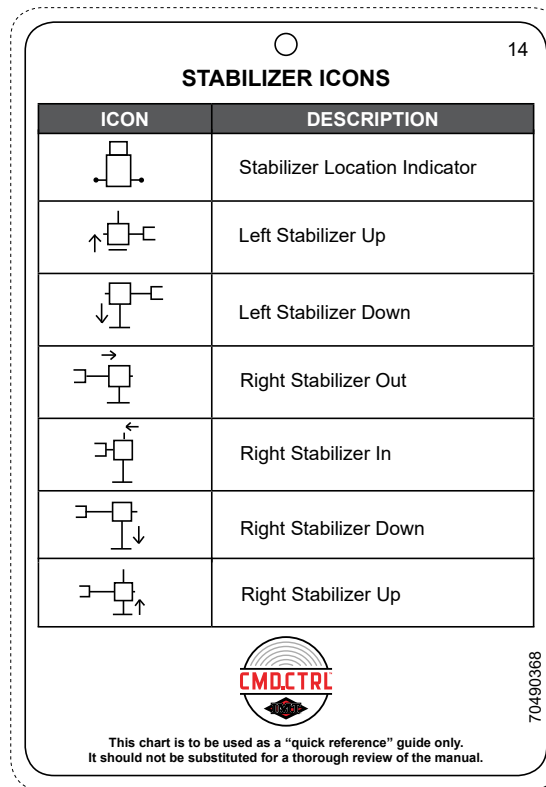

Figure 50

### 11.14 Cab Controls

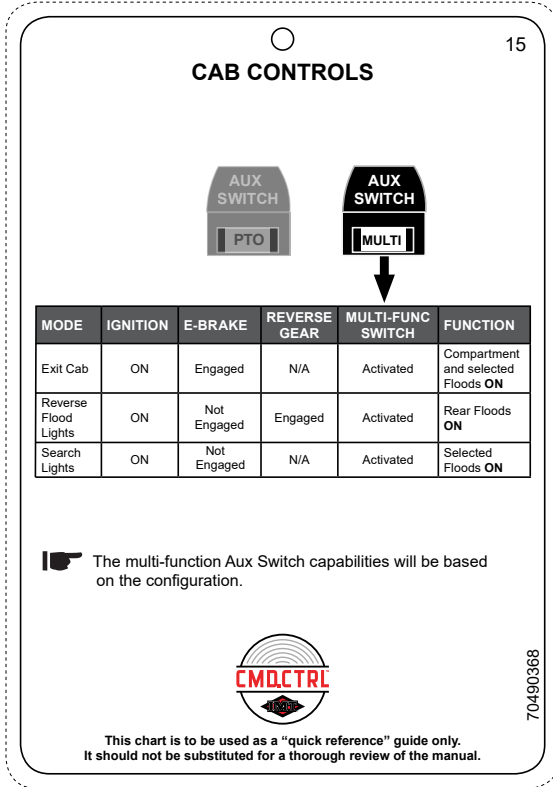

Figure 51

### 11.15 Association

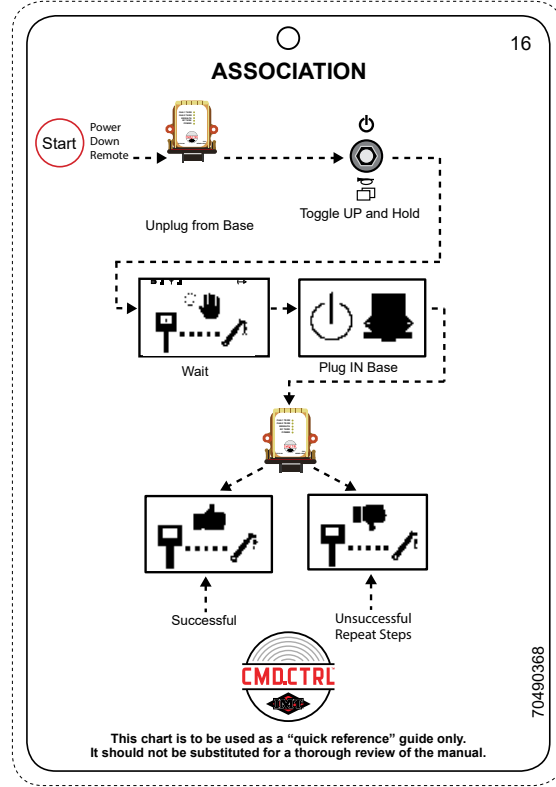



Figure 52

## 11.16 GM/IH CV CHASSIS PTO SETUP

17

### GM / IH CV CHASSIS PTO SETUP

Upon arrival at the worksite and while the engine is running:

1. Engage the E-Brake.
2. Enable the cruise control from the steering wheel controls, then disable the cruise control while observing the indicator light on the dash. (Enable: light is on, Disable: light is off)
3. Engage the PTO by either using:
  - In-dash switch inside the cab.
  - CMD.CTRL™ body controls (Crane remote, or Auto PTO)

**NOTE:**  
If the CMD.CTRL body controls were used for engine **STOP**, you must wait a minimum of 30 seconds before remote **START** can be activated. Attempting a remote **START** in less than 30 seconds from remote engine **STOP**, can result in chassis, or PTO not responding. If the PTO has been disengaged, the GM and IH CV chassis requires a minimum 30 seconds to reconfigure before PTO engage can be activated by either using:

- In-dash switch inside the cab
- CMD.CTRL™ body controls (Crane remote, or Auto PTO)

**NOTE:**  
The horn will honk three (3) times indicating when the PTO is starting. If after 15 seconds the PTO has **NOT** started, repeat the PTO engage request. It is not uncommon for the PTO engage to **NOT** respond after multiple attempts with a GM and IH CV chassis. If the PTO will **NOT** engaged after multiple attempts, the chassis will need to be reset by:

- Turning engine off and removing the ignition key.
- Waiting until the chassis has completely powered down. (This can take up to one minute)



This chart is to be used as a "quick reference" guide only.  
It should not be substituted for a thorough review of the manual.

70490368

Figure 53

## 11.17 Telescopic Crane Parts Manuals QR Codes

91729048  
3300(e)&4300(e)  
Parts & Specs



91729049  
5300(e)&6300(e)  
Parts & Specs



91729050  
7600/8600 27' & 23'  
Parts & Specs



91729051  
10600/12600 25' & 30'  
Parts & Specs



91729121  
14000 25' & 30'  
Parts & Specs



## 11.18 Association—Programming

To associate, there must be a clear line of sight between the handheld remote and the base unit. Both units must be OFF (powered down). Association cannot occur while tethered. Power down the handheld remote either by depressing the STOP button, or by flipping the RFF toggle UP. Power down the base unit either by unplugging P1 Connector, or by removing the source power from the unit.

Do not operate the trigger while Associating.

1. Power down the handheld remote by clicking the RFF toggle UP for one-second.
2. Power down the base by unplugging the connector on the bottom side of the receiver (Installed on the outside of crane mast).

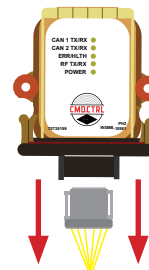

Figure 54

3. Toggle **UP** and continuously **HOLD** the **RFF POWER ON** toggle (the screen in *Figure 59* will appear) until the Association process has been completed.

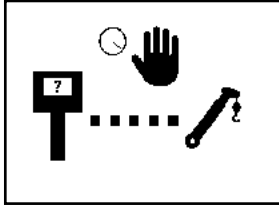

Figure 55

4. When the **POWER UP BASE** screen appears (*Figure 60*) on the remote, plug in the connector on the bottom side of the base installed on the outside of the crane mast. (See *Figure 61*).



Figure 56

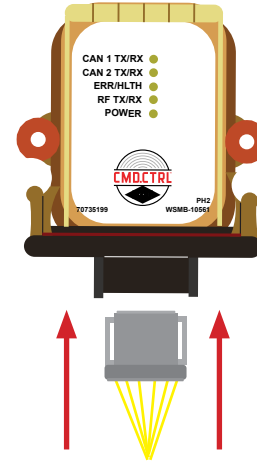
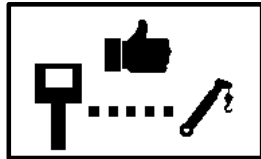
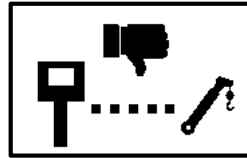

Figure 57

5. When the Association Successful screen appears, the handheld remote and the base unit has been successfully associated. (Thumbs up = connected).
6. If the Association Unsuccessful screen appears the association has failed. (Thumbs down = not connected) Restart the process from Step 1.



Association Successful  
Thumbs Up



Association Unsuccessful  
Thumbs Down

*Figure 58*



## 12.0 Safety Decals

### 12.1 Safety Decal Parts List

(Illustration not shown)

PART NO.	QTY.	DESCRIPTION
70391598	2	DECAL-WARNING MAN STABILIZER
70392864	4	DECAL-WARNING STAB STAND CLEAR
70392868	7	DECAL-WARNING CR LOADLINE (TRK) LARGE
70392891	1	DECAL-DANGER DRIVELINE
70394445	4	DECAL-DANGER ELEC HZD LG TELE
70396613	1	DECAL-CRANE SAFETY & OPER
70394189	1	DECAL-HYDRAULIC OIL RESERVOIR
71039134	1	DECAL-CAUTION OIL LEVEL
70392982	1	DECAL-SERVICE & REPAIR (GARNER)

PART NO.	QTY.	DESCRIPTION
70399271	3	DECAL-STAB FULLY DEPLOYED
71392365	1	DECAL-ALIGNMENT CRANE ROTATION
70399490	1	DECAL-INSTALL & STAB TESTING BY
70490167	1	DECAL-WARNING-PROP 65
70396748	1	DECAL-DANGER ELEC HZD SML TELE
70392213	1	DECAL-CAUTION DONT WASH/WAX
70490146	1	DECAL-STABILITY CAPACITY CHART
70392863	1	DECAL-WARNING CR LOADLINE (TRK) SMALL

Table 16



# Index

## A

### Adverse Weather Conditions

Dusty and Sandy Areas .....	13
High Altitudes.....	13
High Humidity and Salt Air .....	13

## B

### Basic Hitches

BASKET.....	45
CHOKER .....	45

## C

Company Address .....	2
IMT Technical Support / Parts and Service .....	2
NHTSA.....	9
OSHA 9, 9–80	
Crane Shutdown	
Disengage the throttle control.....	31
Retract the extension boom.....	31
Secure loose items on truck bed .....	31
Secure the hook.....	31
Stow the crane.....	31
Stow the stabilizers.....	31

## H

BASKET .....	45
--------------	----

CHOKER .....	45
Hitches.....	44, 45
BASKET.....	45
CHOKER .....	45

## I

ISO VG32 .....	34
----------------	----

## L

Lock-Out Tag-Out .....	32
------------------------	----

## M

Maximum Horizontal Reach .....	37
--------------------------------	----

## O

overload protection .....	29
Overload Protection	
overload protection system stops the following functions at the point of overload:.....	29

## P

Personal Protective Equipment .....	5, 26, 32
Pre-Operation Inspection Checklist.....	53
ANNUAL .....	53
MONTHLY .....	53
QUARTERLY .....	53
Preparing the Worksite	
work zone .....	17

---

## R

Radio Receiver Display (Base Unit)	
Display Messages Table .....	30

## S

SAE J765a.....	35, 36, 37
Safety Information .....	1
Stability	
Example.....	38
Stability Test.....	35
Stability Testing.....	35
Set-Up.....	35
Stability Chart	
Example.....	38
Stable Horizontal Reach.....	37

## T

tipping point.....	36
--------------------	----

## W

WIRE ROPE INSPECTION CRITERIA	
IDLE EQUIPMENT .....	45
INSPECTOR.....	44
METHODS OF INSPECTION.....	45
PERIODS OF INSPECTION.....	44



REVISIONS		



An Oshkosh Corporation **Business**

**IOWA MOLD TOOLING CO., INC.**

P.O. Box 189 Garner, IA 50438

Tel: 641-923-3711

[www.imt.com](http://www.imt.com)



**OSHKOSH™**

IMT is an Oshkosh Corporation Business  
Oshkosh is a registered trademark and the Oshkosh logo is a trademark of Oshkosh.

IMT reserves the right to make changes in engineering, design, specifications, add improvements or discontinue manufacturing at any time without notice or obligation.

IMT and IMT LOGO are registered trademarks of Iowa Mold Tooling Co., Inc., Garner, IA, USA.

© 2026 Iowa Mold Tooling Co., Inc. All Right Reserved.